



PROTECTION RELAYS

N-DIN-TO64-RFI (RFI APPROVED)

D.C. current relay with high sensitivity hall effect transducer

The relay N-DIN-TO64 connected to the magnetic detector TO64 allows for very accurate measurement of DC current on a rated current of over 1000A. The operation of the relay can be unidirectional or bidirectional. The rated insulation voltage of the magnetic detector TO64 is over 5kV (dielectric test voltage 10kV-50Hz 1 min or 15kV on request).

The N-DIN relay is surface mounted on standard DIN-EN 50022 rail, but its Front-Face Panel (FFP) including Controls, Signals and Display, is removable and can be flush mounted, apart from the Relay Main Body (RMB), on the front panel of the switch board or of the MCC drawers. When removed, the FFP is connected to the RMB via a dedicated serial link by a normal wire and screw

terminals. One FFP only can control and supervise up to 31 RMB units. Another RS232 port is available on the FFP front for local connection to a PC.

Similarly the RMB, besides the Serial Port connecting the FFP, has another RS485 serial port, with screw terminals, for connection to the serial bus of the DCS. The relay main body RMB can be used as a stand-alone unit, without the front panel FFP.

Protective Functions

- F64 : Two Earth fault protection element.
- F51BF : Breaker Failure protection.

Measurements

- Measurement of input earth current (Primary Ampere).



MICROELETTRICA

Control

- 1 Programmable output relay (R2).
- 1 Analogic output (4 --ä 20)mA.
- Load Profile.
- Operation counters.
- Event recording.
- 3 Digital Inputs.
(Reset, Remote trip / C/B status, Blocking input)

Technical Characteristics

FFP

- Display 2x16 characters.
- 4 signal leds.
- 4 push-button.

RMB

- 2 signal led.
- 1 Reset button.

Communications

FFP

- 1 RS232 serial port (front)
- 1 RS485 serial port (rear)

RMB

- 1 RS485 port for connection to the communication serial bus.
- 1 RS485 port for communication to the Front Face Panel. (FFP Option).
- Communication protocol is MODBUS-RTU for all the Ports.

Power Supply Ratings

- Type 1 : 24V(-20%) / 80V(+15%) a.c. - 24V(-20%) / 90V(+20%) d.c.
- Type 2 : 80V(-20%) / 230V(+15%) a.c. - 90V(-20%) / 250V(+20%) d.c.

Mounting

- DIN46227 (EN50022)

Software

- MCom program interface for device management.

F64 (I>): First overcurrent element		
Function enabling	Enable/Disable	
Setting range	I> = (4 ÷ 100)%In	step 1%In
Instantaneous output	≤ 0.03s	
Independent time delay	tI> = (0.03 ÷ 60)	step 0.01s
Trip detection	Bidirectional / Positive / Negative	
F64 (I>>): Second overcurrent element		
Function enabling	Enable/Disable	
Setting range	I> = (4 ÷ 100)%In	step 1%In
Instantaneous output	≤ 0.03s	
Independent time delay	tI> = (0.03 ÷ 60)	step 0.01s
Trip detection	Bidirectional / Positive / Negative	
Breaker Failure Element		
Trip time delay	tBF = (0.05 ÷ 0.75)s	step 0.01s

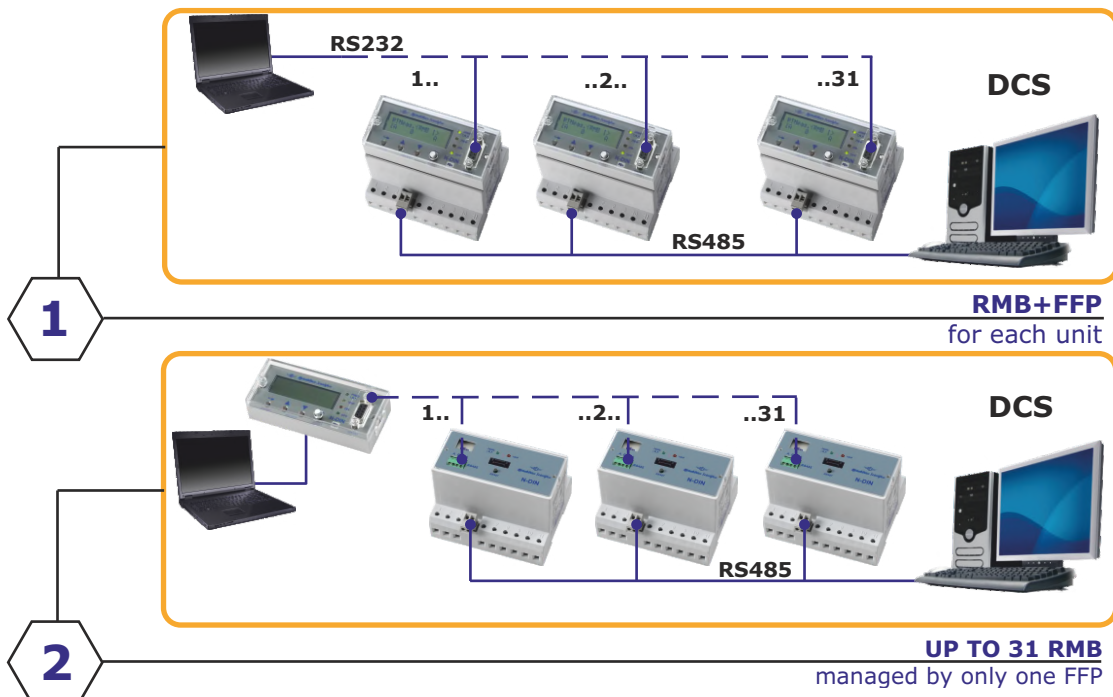

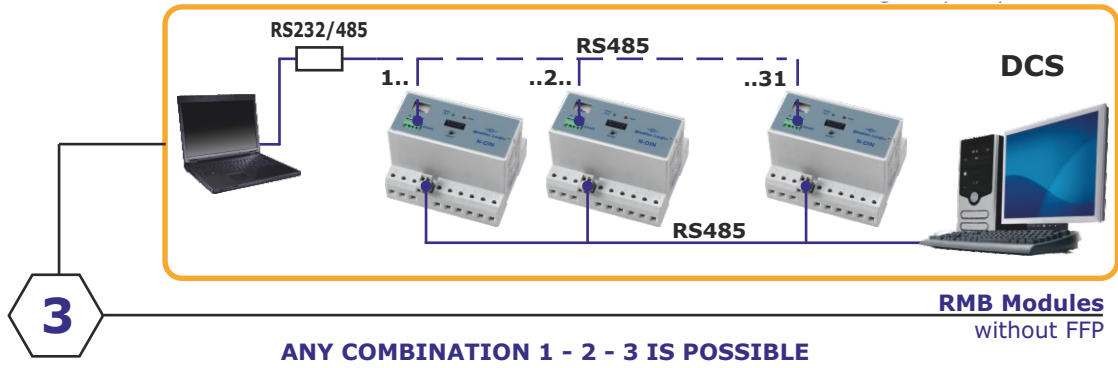

TRASPARENT COVER - Dimensions = 45x108 - Height = 9

REMOVABLE
FRONT FACE
(FFP)

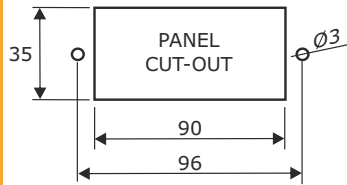

(mm)

FFP - Height = 16

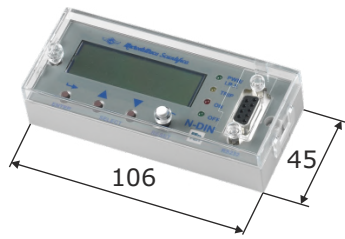

RMB - Height = 72

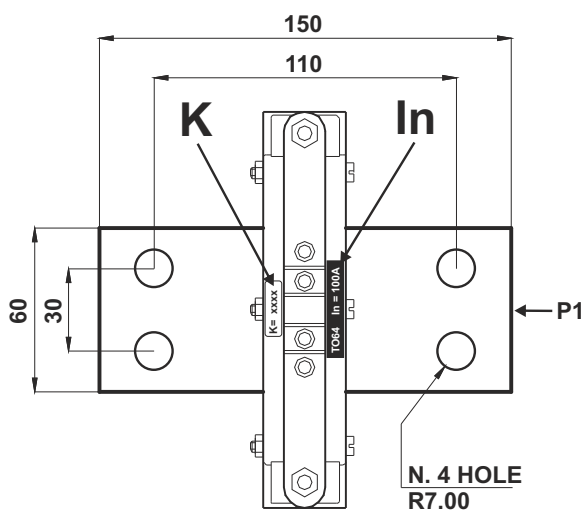
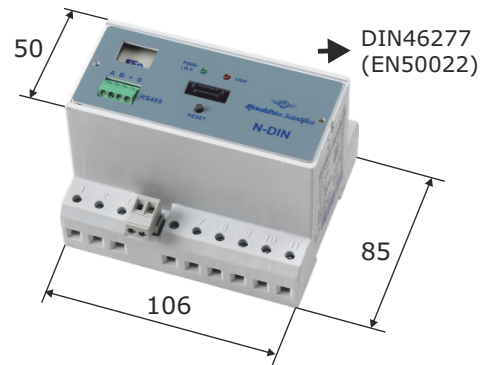

(mm)

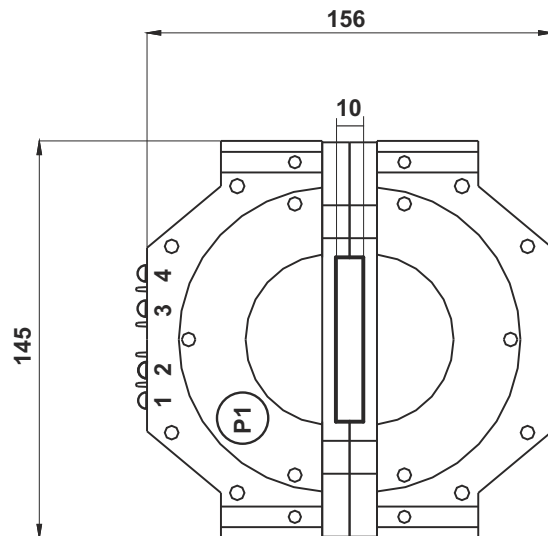

Connection Diagram

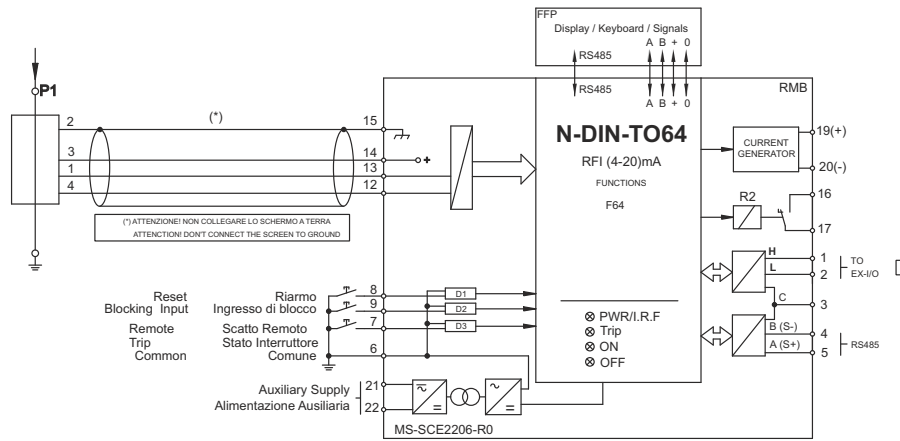

Typical characteristics - N-DIN

Accuracy at reference value of influencing factors	5%	for measurement with max 1% of FS
	2% ± 10ms	for times
Input	from magnetic detector TO64	
Average power supply consumption	≤ 10 VA	
Output current	ating 6 A; Vn = 250V A.C. resistive switching = 1500W (400V max)	
	make = 30 A (peak) 0.5 sec., break = 0.3 A, 110 Vcc, L/R = 40 ms (100.000 op.)	
	L/R = 40 ms (100.000 op.)	
In option to relay R1 Relè in opzione al relè R1	4 ÷ 20mA (0 ÷ 12)mA	

Typical characteristics - Magnetic Detector

Frequency response	0 ÷ 100 kHz					
Maximum distance „Relay/magnetic detector“	<10 meters (shielded cable)					
Type	In (A) Rated Input Current	(*) Ith (A) Max. admissible continuous overload	Vn (Vcc) Rated Input Voltage	Measurement Range (A)	Dielectric withstand Vol- tage 1'@50Hz (kV)	Maximum Dinamic Current (kA per 1s)
TO64 - 100	100	1000	1000	4 ÷ 100	10	100
TO64 - 500	500	1000	1000	20 ÷ 500	10	100
TO64 - 100H	100	1000	5000	4 ÷ 100	18.5	100
TO64 - 500H	500	1000	5000	20 ÷ 500	18.5	100

(*) on request other value

Order Code - Example

N-DIN-TO64-RFI	1	1
	Power Supply	Options
	1 = Type 1	1 = Standard (RMB+FFP)
	2 = Type 2	2 = Only RMB
		3 = Only FFP

The technical specifications reported are not binding and they should be agreed in the contract.

For further technical information on our products visit www.microelettrica.com

Microelettrica Scientifica S.p.A.

20090 Buccinasco (MI) , Via Lucania 2, Italy

Tel.: +39 02 575731

E-mail: info@microelettrica.com

www.microelettrica.com



KNORR-BREMSE

NEW YORK AIR BRAKE

IFE

MERAK

MICROELETTRICA

SELECTRON

KIEPE ELECTRIC

EVAC

ZELISKO

RAILSERVICES