



N-DIN-T064

D.C. current relay with high sensitivity
hall effect transducer

Features

The relay N-DIN-T064 connected to the magnetic detector TO64 allows for very accurate measurement of DC current on a rated current of over 1000A.

The operation of the relay can be unidirectional or bidirectional. The rated insulation voltage of the magnetic detector TO64 is over 5kV (dielectric test voltage 10kV-50Hz 1 min or 15kV on request).

The N-DIN relay is surface mounted on standard DIN-EN 50022 rail, but its Front-Face Panel (FFP) including Controls, Signals and Display, is removable and can be flush mounted, apart from the Relay Main Body (RMB), on the front panel of the switch board or of the MCC drawers.

When removed, the FFP is connected to the RMB via a dedicated serial link by a normal wire and screw terminals. One FFP only can control and supervise up to 31 RMB units. Another RS232 port is available on the FFP front for local connection to a PC.

Similarly the RMB, besides the Serial Port connecting the FFP, has another RS485 serial port, with screw terminals, for connection to the serial bus of the DCS. The relay main body RMB can be used as a stand-alone unit, without the front panel FFP.



MICROELETTRICA

The Relay Main Body (RMB)

- 3 Digital Inputs (Reset, Remote Trip, C/B Status, Blocking Input)
- 2 Programmable output relays each with one N.O. contact rating 6A
- 1 RS485 Serial port for connection to the communication serial bus.
- 1 RS485 port for communication to the Front Face Panel.
- Il protocollo di comunicazione è MODBUS-RTU per tutte le porte.
- 2 Signal Leds
- 1 Reset button

Power Supply Ratings

Isolated multivoltage autoranging Power Supply input: two options available

Type 1 : 24V(-20%) / 80V(+15%)a.c. - 24V(-20%) / 90V(+20%)d.c.

Type 2 : 80V(-20%) / 230V(+15%)a.c. - 90V(-20%) / 250V(+20%)d.c.

The Front Face Panel (FFP)

2 x 16 characters LCD display for real time measurements of input quantities programming and reading-out of relay settings, event discrimination etc....

Four Key buttons for local relay management

Four signal leds

One RS232 (USB) port for connection to a local PC (on front side)

One RS485 port for interconnection with the RMB (on back side)

Measurements

Measurement of input earth current (Primary Ampere).

Load Profile.

Trip and Operation Counters.

Event recording with value of the parameters at the moment of tripping and time tagging.

Display of programmed parameter settings.

Protection Functions

F64 - Two Earth fault protection element.

F51BF - Breaker Failure protection.

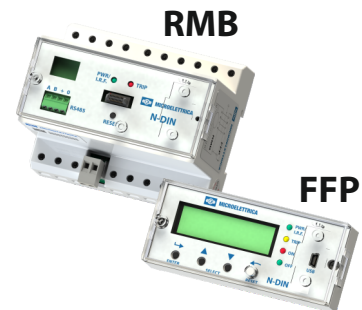

TO64 - Overall Dimensions (mm)

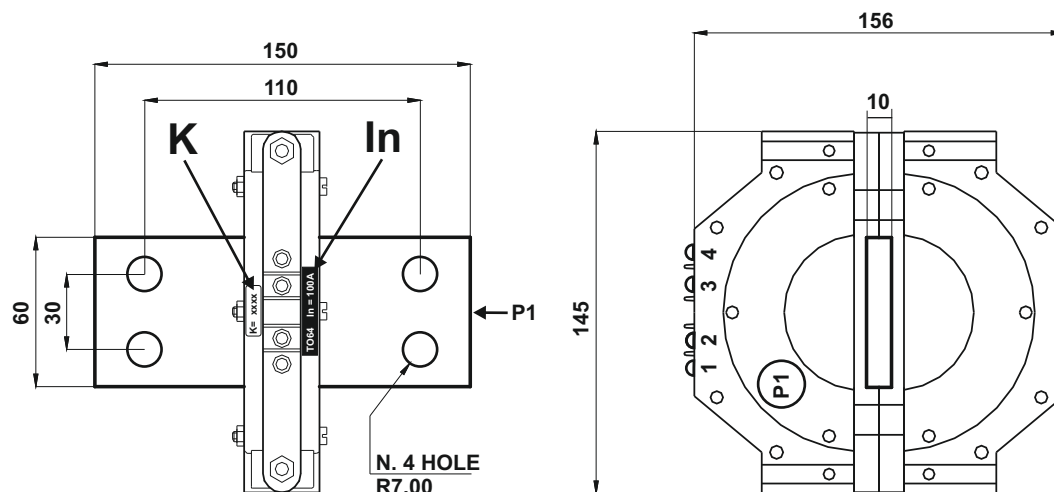

FFP - Overall Dimensions (mm)

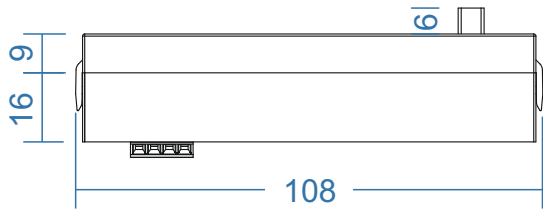

With Cover

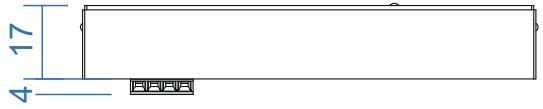
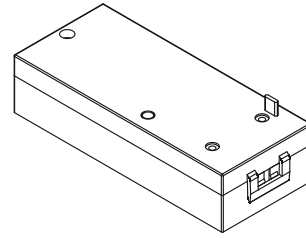

Without Cover

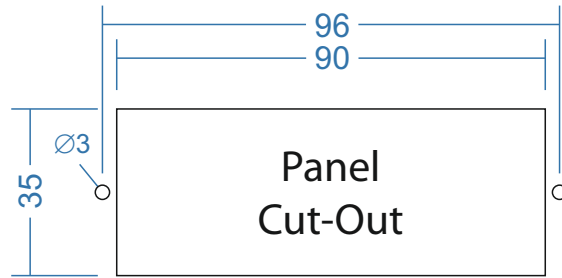
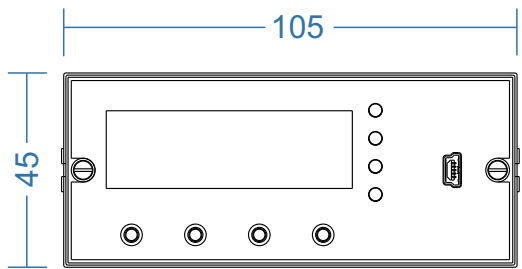
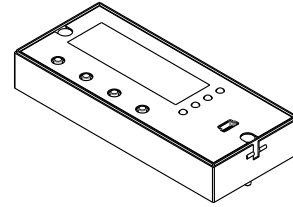

Panel
Cut-Out

RMB - Overall Dimensions (mm)

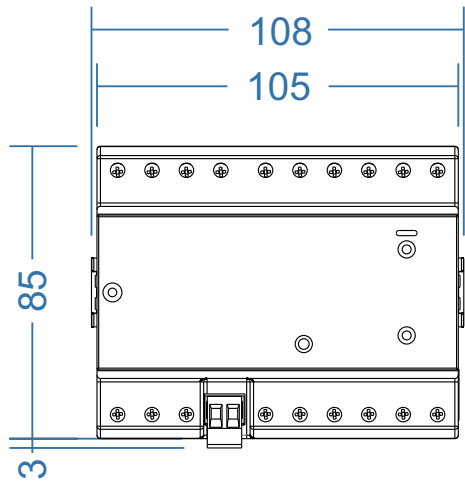

DIN46277
(EN50022)

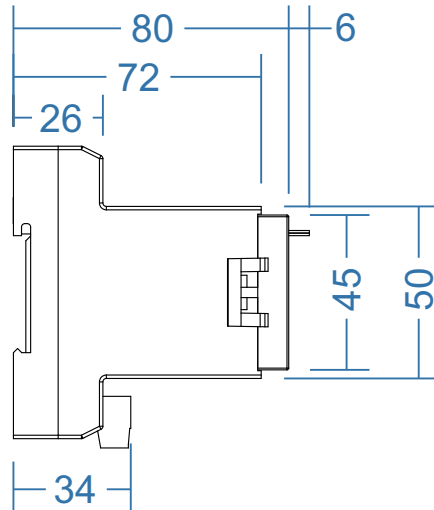

With Cover

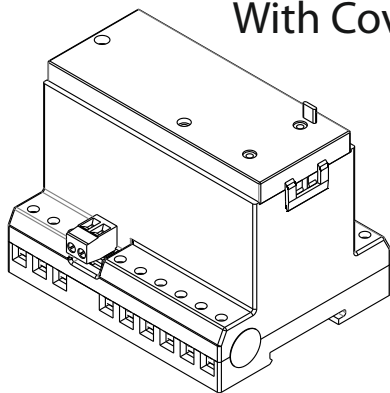

Without
Cover

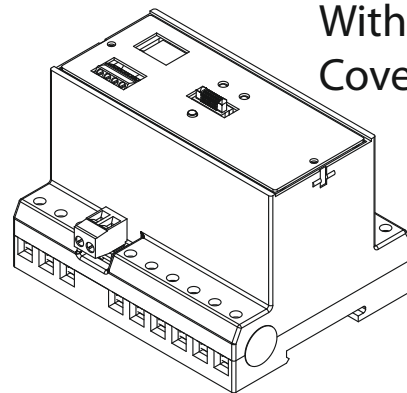

Approval : CE

Reference Standards IEC 60255 - EN50263 - CE Directive - EN/IEC61000 - IEEE C37

Dielectric test voltage	IEC 60255-5	2kV, 50/60Hz, 1 min.
Impulse test voltage	IEC 60255-5	5kV (c.m.), 2 kV (d.m.) - 1,2/50µs
Insulation resistance		>100 M

Environmental Std. Ref. (IEC 60068-2-1 - 68-2-2 - 68-2-33)

Operation ambient temperature		-10 C / +55 C
Storage temperature		-25 C / +70°C
Humidity	IEC60068-2-3	RH 93% Without Condensing at 40°C

CE EMC Compatibility (EN61000-6-2 - EN61000-6-4 - EN50263)

Electromagnetic radiated and conducted emission	EN55022			industrial environment
Radiated electromagnetic field immunity test	IEC61000-4-3	level 3	80-1000MHz	10V/m
	ENV50204		900MHz/200Hz	10V/m
Conducted disturbances immunity test	IEC61000-4-6	level 3	0.15-80MHz	10V
Electrostatic discharge test	IEC61000-4-2	level 3	6kV contact / 8kV air	
Power frequency magnetic test	IEC61000-4-8		1000A/m, 50/60Hz	
Pulse magnetic field	IEC61000-4-9		1000A/m, 8/20µs	
Damped oscillatory magnetic field	IEC61000-4-10		100A/m, 0.1-1MHz	
Electrical fast transient/burst	IEC61000-4-4	level 3	2kV, 5kHz	
HF disturbance test with damped oscillatory wave (1MHz burst test)	IEC60255-22-1	class 3	400pps, 2,5kV (m.c.), 1kV (d.m.)	
Oscillatory waves (Ring waves)	IEC61000-4-12	level 4	4kV(c.m.), 2kV(d.m.)	
Surge immunity test	IEC61000-4-5	level 4	2kV(c.m.), 1kV(d.m.)	
Voltage interruptions	IEC61000-4-29		0% 50ms	
Resistance to vibration and shocks	IEC60255-21-1 - IEC60255-21-2		10-500Hz 1g	

Typical Characteristics

Input	from magnetic detector TO64
Auxiliary power supply	Type 1 - Type 2
Average power supply consumption	<10VA
Output relays	rating 6 A; Vn = 250 V
Software interface	MCom

Typical characteristics - Magnetic Detector

Frequency response	0 ÷ 100 kHz
Maximum distance "Relay/magnetic detector"	<10 meters (shielded cable)

Type	In (A) Rated Input Current	Ith (A) Max. admissible continuous overload	Vn (Vcc) Rated Input Voltage	Measurement Range (A)	Dielectric withstand Voltage 1'@50Hz (kV)	Maximum Dinamic Current (kA per 1s)
TO64 - 100	100	1000	1000	4 ÷ 100	10	100
TO64 - 500	500	1000	1000	20 ÷ 500	10	100

Connection Diagram

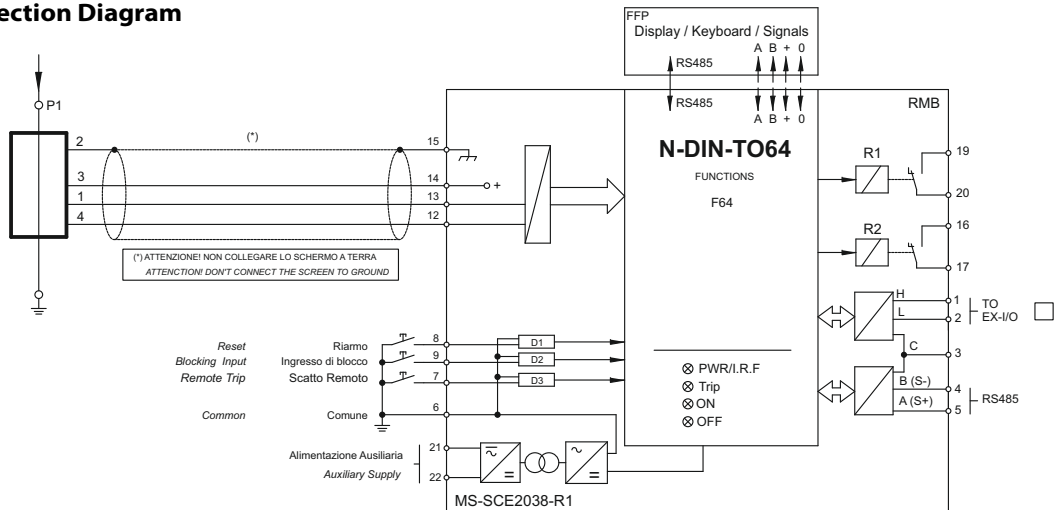

N-DIN-TO64

Order Code	Auxiliary Voltage (Vaux)	Component
NT1100000C	24V(-20%) / 80V(+15%)ac - 24V(-20%) / 90V(+20%)dc	Remote + Main Unit
NT1200000C	80V(-20%) / 230V(+15%)ac - 90V(-20%) / 250V(+20%)dc	Remote + Main Unit
NT1100001C	24V(-20%) / 80V(+15%)ac - 24V(-20%) / 90V(+20%)dc	Remote + Main Unit + TO64 (100A)
NT1200001C	80V(-20%) / 230V(+15%)ac - 90V(-20%) / 250V(+20%)dc	Remote + Main Unit + TO64 (100A)
NT1100005C	24V(-20%) / 80V(+15%)ac - 24V(-20%) / 90V(+20%)dc	Remote + Main Unit + TO64 (500A)
NT1200005C	80V(-20%) / 230V(+15%)ac - 90V(-20%) / 250V(+20%)dc	Remote + Main Unit + TO64 (500A)

Spare Parts

Order Code	Auxiliary Voltage (Vaux)	Component
NT1100000M	24V(-20%) / 80V(+15%)ac - 24V(-20%) / 90V(+20%)dc	Main Unit (RMB)
NT1200000M	80V(-20%) / 230V(+15%)ac - 90V(-20%) / 250V(+20%)dc	Main Unit (RMB)
NT1000000R	-----	Remote Unit (FFP)
NT100000A0	-----	TO64 (100A) Magnetic Detector
NT100000B0	-----	TO64 (500A) Magnetic Detector
NT40000002	length 2 meters (*)	Connection Cable

(*) on request other length

The technical specifications reported are not binding and they should be agreed in the contract.

For further technical information on our products visit www.microelettrica.com

Microelettrica Scientifica S.p.A.

20090 Buccinasco (MI) , Via Lucania 2, Italy

Tel.: +39 02 575731

E-mail: info@microelettrica.com

www.microelettrica.com



 **KNORR-BREMSE**

 **NEW YORK AIR BRAKE**

 **IFE**

 **MERAK**

 **MICROELETTRICA**

 **SELECTRON**

 **EVAC**

 **ZELSKO**

 **RAILSERVICES**