

Switches

Standard Family Code TADN1250P3E02

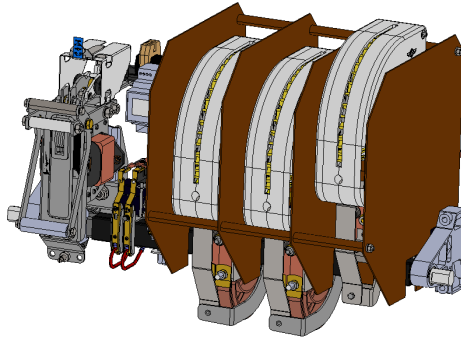

Description

Contactor with single interruption in air, electromagnetic control by two coils (one for close and one for open), and also handle lever.

Double state functioning thanks to mechanical latching device.

Reference standard ANSI-IEEE CE 37.18-1979 and C37.16-1988.

Type	TADN 1250
Number of Poles	2 NO + 1 NC
Connection between poles	Series for NO pole ¹
Mounting Position	Vertical
Control Voltage Rating U _c [Vdc]	110Vdc/Vac - 220Vdc/Vac ¹
Auxiliary Contact Blocks	5 NO + 5 NC
Block Type	B
Arc chute Material	Ceramic in plastic shells
Main Contacts tips Material	S6 (NO pole) - S4 (NC pole)
Arcing Contacts tips Material	-
Electric Diagram 110V / 220V	SCE1552 / SC26303
Layout Drawing	D53577

¹ To be specified in order phase.

Electrical Characteristics

Rated Nominal Voltage Class V _n [V _{ac} / V _{dc}]	1000
Rated Insulation Voltage U _i [V]	1000
Characteristics of the main Contacts (2 Poles NO Series)	
Conventional Free Air Thermal Current I _{th} [A] at 40°C ²	1250
Conventional Free Air Thermal Current I _{th} [A] at 60°C ²	1100
Rated short-time voltage of main contacts V' [V _{dc}]	700
Rated interruption current I' _{cc} of main contacts at V' (short-circuit in the field circuit) [kA]	20
Rated maximum interrupting voltage of main contacts V _{cc} [V _{dc}]	1000
Rated interruption current I _{cc} of main contacts at V _{cc} (short-circuit in the armature circuit) [kA]	10
Rated 1/2 second short-time current I _{cc} 0,5 [kA]	20
Average impedance per pole at 50 Hz [μOhm]	300
Blow out type	Direct
Characteristics of Normally Closed Contact	
Rated continuous current I _{nd} [A]	1250
Rated interrupting current I _{ccd} of the discharge contacts at V' [kA]	10
Rated making current of the discharge contacts I _{chd} (short-circuit in the armature circuit) [kA]	10
Rated 15 seconds short-time current I _d 15" [kA] of the discharge contacts	6
Blow out type	Direct
Contact Overlap between NO & NC Poles	
Time from NC closing and NO opening [ms]	2 ÷ 3
Time from NO closing and NC opening [ms]	3 ÷ 5

² Device cabled according IEC 60947

Minimum clearances [mm] from:				
Rated Operational Voltage	X	Y	Z	
1000	Metal Parts	100	50	30
	Plastic Parts	50	30	20

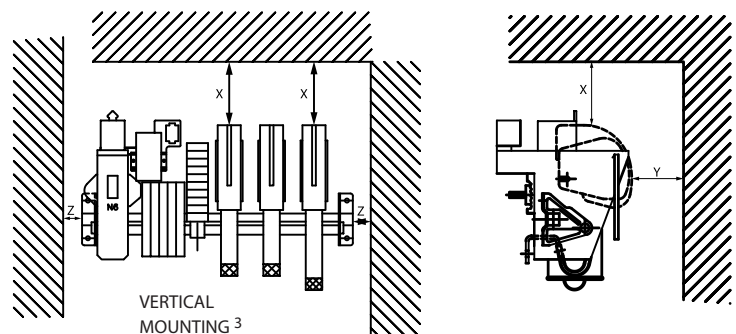

³ OTHER MOUNTING POSITIONS NOT ALLOWED

Switches

Standard Family Code
TADN1250P3E01

Mechanical Characteristics

Mechanical Endurance (cycles) ⁴	2.5x10 ⁵
Weight [kg]	56

Control Circuit

Control Voltage Range	0.85U _c ÷ 1.1U _c
Power Consumption (U _c and T = 20°C) at Closing - When holding - at Opening [W]	950 - 0 - 200
Mechanical Operation Time (U _c and T = 20°C) when Closing - Opening [ms]	90 - 15
Mechanical Operation Time (in the worst condition) when Closing - Opening [ms]	350 - 20
Time Constant (L/R) at Pick Up - when Holding [ms]	
Electrical Connections	Terminal board

Auxiliary Contacts

Tips material	Solid Silver
Rated Operational Voltage [V _{ac} / V _{ac}]	250
Rated Current [A]	10
Minimum Switching Current at 16V _{ac} [mA] ⁵	100
Electrical Connections	Fast-On 6.35x0.8mm

Environmental Conditions

Stock Temperature Range	-25°C ÷ +60°C
Operational Temperature Range	-5°C ÷ +55°C
Max Altitude without Performance Derating [m]	2000

⁴ With respect of the maintenance operations

⁵ In clean and dry conditions



KNORR-BREMSE