

Switches

Standard Family Code TADN0125P3E00

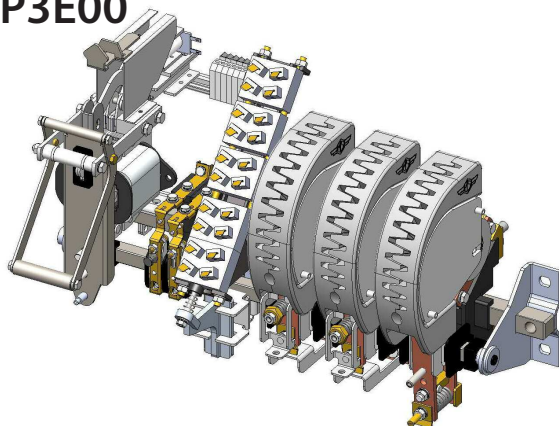

Type	TADN 125
Number of Poles	2 NO + 1 NC
Connection between poles	Series for NO pole ¹
Mounting Position	Vertical
Control Voltage Rating U_c [Vdc]	110Vdc/Vac - 220Vdc/Vac ²
Auxiliary Contact Blocks	5 NO + 5 NC
Block Type	B
Arc chute Material	Plastic shells
Main Contacts tips Material	S6 (NO pole) - S4 (NC pole)
Arcing Contacts tips Material	-
Electric Diagram 110V / 220V	SC27101 / SC27102
Layout Drawing	D53580

¹ Series bar connections available under request ² To be specified in order phase.

Description

Contactors with single interruption in air, electromagnetic control by two coils (one for close and one for open), and also handle lever.
Double state functioning thanks to mechanical latching device.
Reference standard ANSI-IEEE CE 37.18-1979 and C37.16-1988.

Electrical Characteristics

Rated Nominal Voltage Class V_n [V_{ac} / V_{dc}]	600
Rated Insulation Voltage U_i [V]	1000
Characteristics of the main Contacts (2 Poles NO Series)	
Conventional Free Air Thermal Current I_{th} [A] at 40°C ³	125
Conventional Free Air Thermal Current I_{th} [A] at 60°C ³	110
Rated short-time voltage of main contacts V' [V_{dc}]	700
Rated interruption current I'_{cc} of main contacts at V' (short-circuit in the field circuit) [kA]	1
Rated maximum interrupting voltage of main contacts V_{cc} [V_{dc}]	1000
Rated interruption current I_{cc} of main contacts at V_{cc} (short-circuit in the armature circuit) [kA]	0.6
Rated 1/2 second short-time current I_{cc} 0,5 [kA]	2
Average impedance per pole at 50 Hz [$\mu\Omega$]	1200
Blow out type	Direct
Characteristics of Normally Closed Contact	
Rated continuous current I_{nd} [A]	125
Rated interrupting current I_{ccd} of the discharge contacts at V' [kA]	0.6
Rated making current of the discharge contacts I_{chd} (short-circuit in the armature circuit) [kA]	1.8
Rated 15 seconds short-time current $I_{d15''}$ [kA] of the discharge contacts	0.9
Blow out type	Direct
Contact Overlap between NO & NC Poles	
Time from NC closing and NO opening [ms]	2 ÷ 3
Time from NO closing and NC opening [ms]	3 ÷ 5

³ Device cabled according IEC 60947

Minimum clearances [mm] from:				
Rated Operational Voltage	X	Y	Z	
1000	Metal Parts	100	50	30
	Plastic Parts	50	30	20

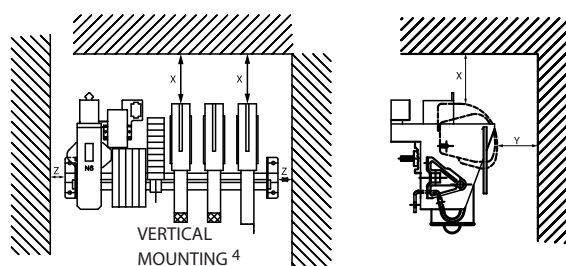

4 OTHER MOUNTING POSITIONS NOT ALLOWED

