

SWITCHES

STANDARD FAMILY CODE N000650P3A01

Type	N 650
Number of Poles	3 NO
Connection between poles	None
Mounting Position	Vertical
Control Voltage Rating U_c [Vdc]	110Vdc/Vac - 220Vdc/Vac ¹
Auxiliary Contact Blocks	5 NO + 5 NC
Block Type	B
Arc chute Material	Ceramic in plastic shells
Main Contacts tips Material	S6
Arcing Contacts tips Material	-
Electric Diagram	TU0165/B (DC) - TU0165/C (AC)
Layout Drawing	D53387

¹ To be specified in order phase.



MICROELETTRICA

Description

Contactors with single interruption in air, electromagnetic control by power save system (economy resistor).
 Typical application 3 Phase AC Motor control. Reference Standard IEC 60947-4-1.

Electrical Characteristics				
Rated Operational Voltage Ue [Vac]	220	380	600	690
Rated Insulation Voltage Ui [Vac]	1000			
Conventional Free air thermal current Ith [at 40°C] ²	650			
Conventional Free air thermal current Ith [at 60°C] ²	570			
Maximum Making Capacity for 100 ms I _{ch} [kA]	10			
Short Circuit Withstand Current for 100 ms I _{cw} [kA]	12			
Average impedance per pole at 50 Hz [MicroOhm]	300			
Blow out circuit type	Direct			
Electrical Characteristics 3NO pole (S6) for AC application				
Rated Operational Voltage [Vac]	220	380	600	690
Maximum Breaking Capacity cosΦ=0,5 I _{acmax} [A]	13818	8000	6325	5500
Utilization Category according to IEC60947-4-1: AC1&AC2&AC3				
Rated Operational Power P _e [kW]	173	300	460	460
Rated Operational Current I _e [A]	600	600	600	482
Utilization Category according to IEC60947-4-1: AC4				
Rated Operational Power P _e [kW]	160	278	375	375
Rated Operational Current I _e [A]	550	550	550	393
Exceptional Maximum Breaking Capacity @ 1000Vac cosΦ=0,5 [A]	4500			

² Device cabled according IEC 60947 ³ Other mounting positions not allowed

Minimum clearances [mm] from:				
Rated Insulation Voltage		X	Y	Z
1000	Metal Parts	100	50	30
	Plastic Parts	50	30	20

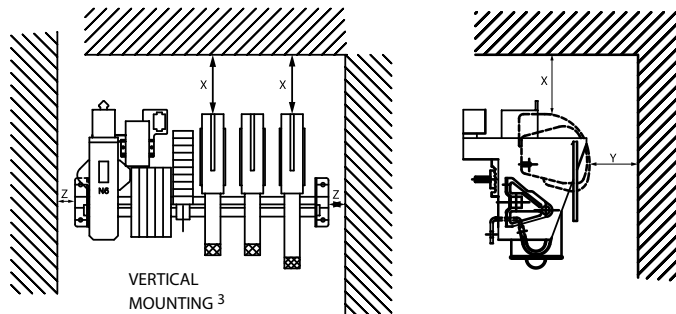

Mechanical Characteristics	
Mechanical Endurance (cycles) ⁴	1x10 ⁶
Weight [kg]	29
Control Circuit	
Control Voltage Range	0.85U _c ÷ 1.1U _c
Power Consumption (U _c and T = 20°C) at Closing - at Opening [W]	300-20
Mechanical Operation Time (U _c and T = 20°C) when Closing - Opening [ms]	70-20
Mechanical Operation Time (in the worst condition) when Closing - Opening [ms]	350-20
Time Constant (L/R) at Pick Up - when Holding [ms]	
Electrical Connections	Fast-On 6.35x0.8mm
Auxiliary Contacts	
Tips material	Solid Silver
Rated Operational Voltage [V _{ac} / V _{dc}]	250
Rated Current [A]	10
Minimum Switching Current at 16V _{dc} [mA] ⁶	100
Electrical Connections	Fast-On 6.35x0.8mm
Environmental Conditions	
Stock Temperature Range	-25°C ÷ +60°C
Operational Temperature Range	-5°C ÷ +55°C
Max Altitude without Performance Derating [m]	2000

⁴With respect of the maintenance operations ⁵ In clean and dry conditions

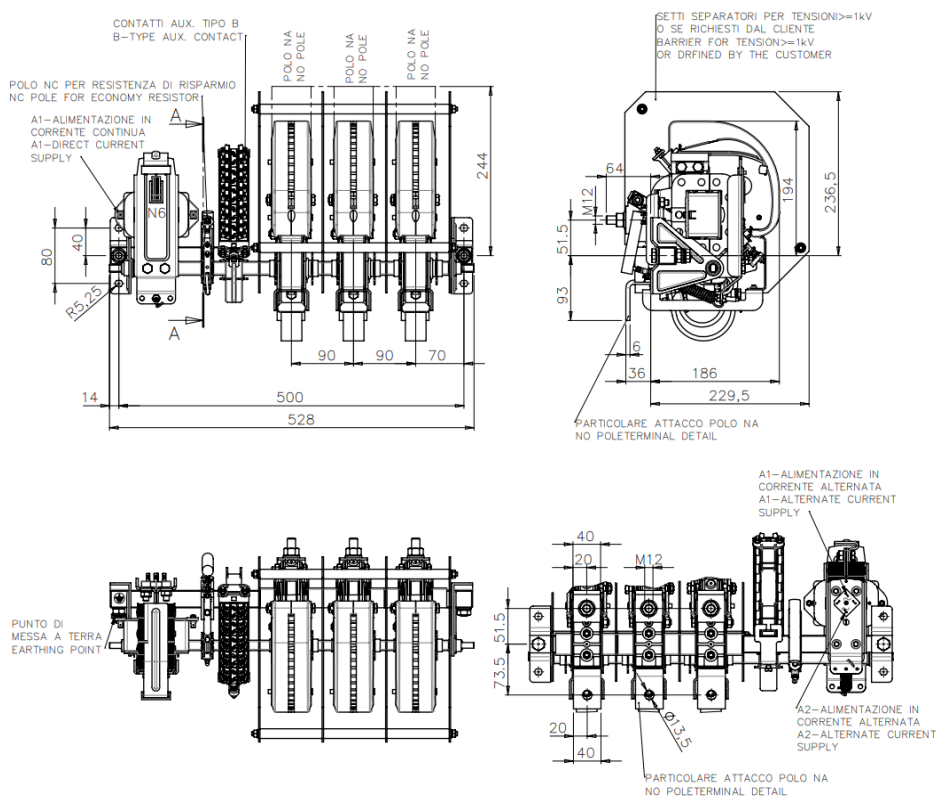

The technical specifications reported are not binding and they should be agreed in the contract.

For further technical information on our products visit www.microelettrica.com

Microelettrica Scientifica S.p.A.

20090 Buccinasco (MI) , Via Lucania 2, Italy

Tel.: +39 02 575731

E-mail: info@microelettrica.com

www.microelettrica.com

