

Switches

Standard Family Code N0000190P3E01

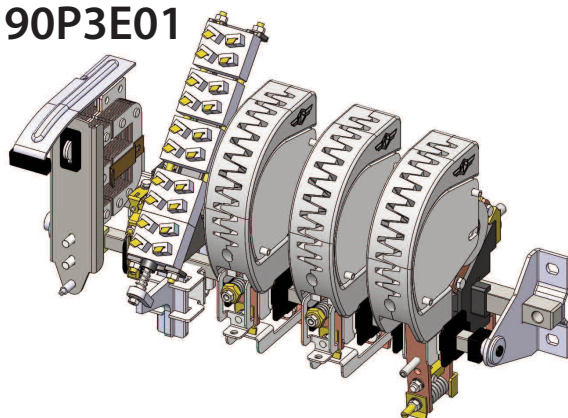

Description

Contactor with single interruption in air, electromagnetic control by power save system (economy resistor). Typical application DC Motor control with braking circuit. Reference Standard IEC 60947-4-1.

Type	N 190
Number of Poles	2 NO + 1 NC
Connection between poles	Series for NO poles ¹
Mounting Position	Vertical
Control Voltage Rating Uc [Vdc]	110Vdc/Vac - 220Vdc/Vac ²
Auxiliary Contact Blocks	5 NO + 5 NC
Block Type	B
Arc chute Material	Plastic shells
Main Contacts tips Material	S6 (NO Pole) - S4 (NC Pole)
Arcing Contacts tips Material	-
Electric Diagram	TU0165/B (DC) - TU0165/C (AC)
Layout Drawing	D53553

¹ Series bar connections available under request

² To be specified in order phase.

Electrical Characteristics

Rated Operational Voltage Ue [Vdc]	220	440	660	750	1000
Rated Insulation Voltage Ui [Vdc]	1000				
Conventional Free air thermal current Ith [at 40°C] ³	190				
Conventional Free air thermal current Ith [at 60°C] ³	165				
Blow out circuit type	Direct				

Electrical Characteristics 2NO poles series connected (S6) for DC application

Rated Operational Voltage [Vdc]	220	440	660	750	1000
Maximum Breaking Capacity tau=15ms Idcmax [A]	3000	2000	1400	1232	924
Utilization Category according to IEC60947-4-1: DC3					
Max Operational Power Pe [kW]	180	180	180	180	180
Max Operational Making and breaking Current Ie [A]	818	409	273	240	180
Utilization Category according to IEC60947-4-1: DC5					
Max Operational Power Pe [kW]	128	128	128	128	0
Max Operational Making and breaking Current Ie [A]	580	290	193	170	0
Maximum Making Capacity for 100 ms Ich [kA]	3				
Short Circuit Withstand Current for 100 ms Icw [kA]	4				
Average impedance per pole at 50 Hz [MicroOhm]	400				

Electrical Characteristics 1NC (S4) for DC application

Rated Operational Voltage [Vdc]	220	440	660	750	1000
Maximum Breaking Capacity tau=15ms Idcmax [A]	950	450	350	0	0
Max Operational Making Current [A]	409	205	136	120	90
Max Operational Breaking Current [A]	259	92	68	0	0
Maximum Making Capacity for 100 ms Ich [kA]	2				
Short Circuit Withstand Current for 100 ms Icw [kA]	3				
Average impedance per pole at 50 Hz [MicroOhm]	600				

³ Device cabled according IEC 60947

Minimum clearances [mm] from:				
Rated Operational Voltage	X	Y	Z	
1000	Metal Parts	100	50	30
	Plastic Parts	50	30	20
1000	Metal Parts	100	50	30
	Plastic Parts	50	30	20

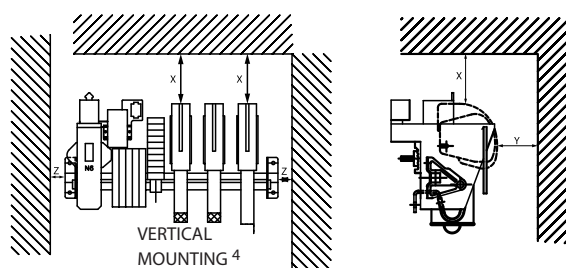

4 OTHER MOUNTING POSITIONS NOT ALLOWED

Switches

Standard Family Code
N000190P3E01

Mechanical Characteristics

Mechanical Endurance (cycles) ⁵	3x10 ⁶
Weight [kg]	8.8

Control Circuit

Control Voltage Range	0.85U _c ÷ 1.1U _c
Power Consumption (U _c and T = 20°C) at Closing - at Opening [W]	130 - 15
Mechanical Operation Time (U _c and T = 20°C) when Closing - Opening [ms]	50 - 15
Mechanical Operation Time (in the worst condition) when Closing - Opening [ms]	200 - 20
Time Constant (L/R) at Pick Up - when Holding [ms]	
Electrical Connections	Fast-On 6.35x0.8mm

Auxiliary Contacts

Tips material	Solid Silver
Rated Operational Voltage [V _{ac} / V _{dc}]	250
Rated Current [A]	10
Minimum Switching Current at 16 V _{dc} [mA] ⁶	100
Electrical Connections	Fast-On 6.35x0.8mm

Environmental Conditions

Stock Temperature Range	-25°C ÷ +60°C
Operational Temperature Range	-5°C ÷ +55°C
Max Altitude without Performance Derating [m]	2000

⁵ With respect of the maintenance operations

⁶ In clean and dry conditions

