

SWITCHES

STANDARD FAMILY CODE LTMP20003XP00

Type	LTMP 2000
Number of Poles	3CO
Mounting Position	Horizontal - Vertical ¹
Control Voltage Rating [V ^{dC}]	24
Auxiliary Contact Blocks	2 CO for each pole
Block Type	V3
Contact Material	Cu
Electric Diagram	SC27714
Layout Drawing	D55582

¹ To be specified in order phase.



MICROELETTRICA

Description

Modular multipole-Multiposition off-load disconnecter, electric motor control without auxiliary relay, 2 position bi-stable. Reference standard IEC 60077-2, IEC 61992 and IEC 60947.

Electrical Characteristics	
Rated Operational Voltage [V_{ac} / V_{dc}]	3600
Max Operational Voltage [V_{ac} / V_{dc}]	4000
Conventional Free Air Thermal Current [A] at 40°C ²	2200
Conventional Free Air Thermal Current [A] at 75°C ²	2000
Main circuit resistance [$\mu\Omega$] ³	50
DC-Rated Operational Current ($\tau=15ms$) [A]	0
DC-Maximum Breaking Capacity ($\tau=5ms$) [A]	0.4
AC-Maximum Breaking Capacity ($\cos\phi=0,8$) [A]	1
Short Circuit Withstand Capacity for 5ms [kA]	180
Component Category / Operational Frequency Class	A4 / C3
Insulation Characteristics	
Rated Insulation Voltage [V]	4000
Pollution Degree - Overvoltage Category (EN 50124-1)	PD3/OV3
Rated impulse voltage [kV]	30
Rated Power Frequency Withstand Voltage (50Hz; 60")	
Between HV circuit to Earth [V]	10000
Between HV to LV circuit [V]	10000
Between open contacts [V]	7900
Between each pole (if more than 1) [V]	7900
Between LV circuit to Earth [V]	1500
Minimum clearance distance Between open contacts [mm]	40
Minimum clearance distance between power circuit to earth [mm]	40
Minimum creepage distance	50
Comparative Tracking Index (CTI) (IEC 60112) [V]	600

² Device cabled according IEC 60947 ³ In new and clean condition for power loss calculation only

⁴ Other mounting positions not allowed, reduced distances should be approved by Microelettrica.

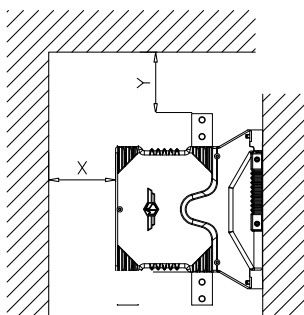

VERTICAL MOUNTING⁴

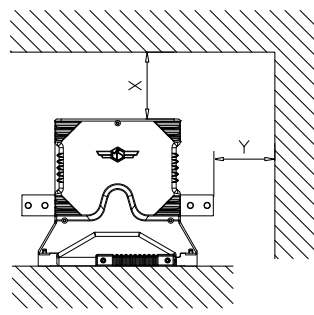

HORIZONTAL MOUNTING⁴

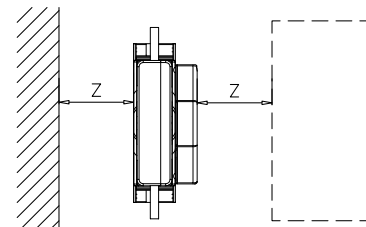

Minimum clearances [mm] from:				
Rated Operational Voltage		X	Y	Z
4000V	Metal Parts	50	50	30
	Plastic Parts	30	30	30

Mechanical Characteristics	
Mechanical Endurance (cycles)	2.5x10 ⁵
Shock and Vibrations (IEC61373)	Cat. 1 - Class B
Weight [kg]	56,5
Control Circuit	
Control Voltage Range	0.7U _c ÷ 1.25U _c
Power Consumption (U _c and T = 20°C) at Pick Up - when Holding [W]	25 - 0 (for each pole)
Mechanical Operation Time (U _c and T = 20°C) when Closing - Opening [ms]	3000 - 3000
Mechanical Operation Time (in the worst condition) [ms]	6000 - 6000
Electrical Connections	Low voltage Connector Souriau SMS12R3
Auxiliary Contacts	
Rated Operational Voltage [Vac / Vdc]	250
Conventional Free Air Thermal Current [A] at 40° C	10
Tips material Rated Current [A]	Silver Alloy (Optional: Golden Plated)
Minimum Let-Through Current at 24/72/110Vdc [mA] ⁵	20(10)/15(7.5)/10(5)
Electrical Connections	Low voltage Connector Souriau SMS12R3
Environmental Conditions	
Stock Temperature Range	-50°C ÷ +85°C
Operational Temperature Range	T _x (-40°C ÷ +75°C) ⁶
Max Altitude without Performance Derating [m]	2500

⁵ Reference standard IEC 60947-5-4. Tested in a DRY and CLEAN condition with an LR load.

For different working conditioins, please contact Microelettrica.

⁶ According to IEC50125-1

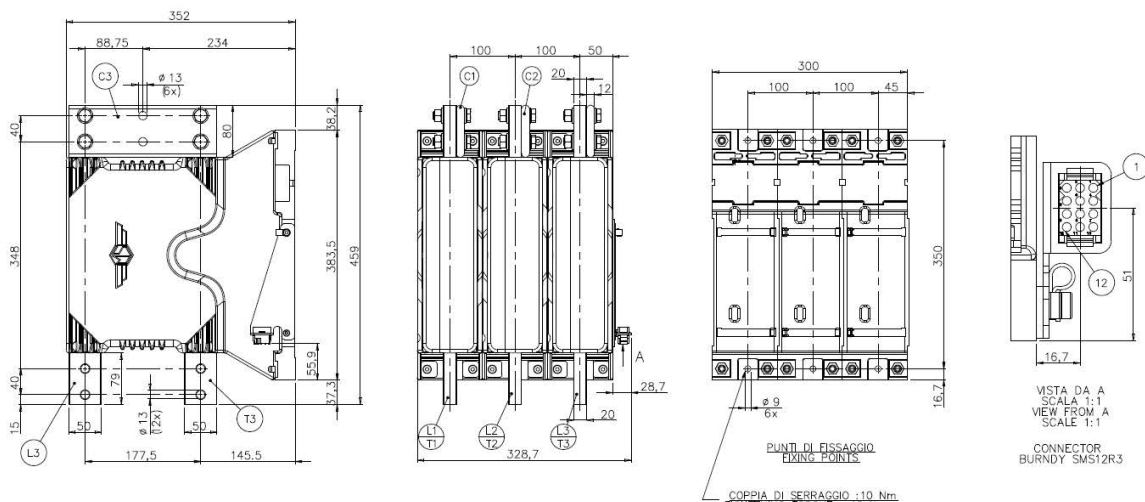

The technical specifications reported are not binding and they should be agreed in the contract.

For further technical information on our products visit www.microelettrica.com

Microelettrica Scientifica S.p.A.

20090 Buccinasco (MI) , Via Lucania 2, Italy

Tel.: +39 02 575731

E-mail: info@microelettrica.com

www.microelettrica.com



KNORR-BREMSE

NEW YORK AIR BRAKE

IFE

MERAK

MICROELETTRICA

SELECTRON

EVAC

ZELISKO

RAILSERVICES