

SWITCHES

STANDARD FAMILY CODE LTKS0901MX000

Type	LTKS900
Number of Poles	1 NO
Mounting Position	Horizontal - Vertical ¹
Control Voltage Rating [V ^{dc}]	24-110 ¹
Auxiliary Contact Blocks	3 (1NO+1NC) + 1CO
Block Type	Integrated
Main Contacts tips Material	Cu
Layout Drawing	D54144
Electric Diagram	SC27631

¹ To be specified in order phase.



MICROELETTRICA

Description

One pole normally opened disconnect switch, electric motor control by electronic device, 2 positions, bi-stable. Reference standard IEC 60077-2

Electrical Characteristics

Rated Operational Voltage [V_{ac} / V_{dc}]	3600
Max Operational Voltage [V_{ac} / V_{dc}]	4200
Conventional Free Air Thermal Current [A] at 40°C ²	1050
Conventional Free Air Thermal Current [A] at 75°C ²	900
Main circuit resistance [$\mu\Omega$] ³	<80
DC-Rated Operational Current ($\tau=15ms$) [A]	0
DC-Maximum Breaking Capacity ($\tau=5ms$) [A]	0.2
AC-Maximum Breaking Capacity ($\cos\phi=0,8$) [A]	0.5
Short Circuit Withstand Capacity for 100ms [kA]	60
Fault Making Capacity @ 100V ($\tau=0ms$) [A]	50
Component Category / Operational Frequency Class	A4 / C3

Insulation Characteristics

Rated Insulation Voltage @ OV4/PD3A [V]	3700
Rated Insulation Voltage @ OV3/PD3 [V]	4800
Rated impulse voltage [kV]	30
Rated Power Frequency Withstand Voltage (50Hz; 60")	
Between HV circuit and LV circuit+Earth [V]	11600
Between open contacts [V]	9200
Between each pole (if more than 1) [V]	11600
Between LV circuit and Earth [V]	1500
Minimum clearance distance between open contacts [mm]	80
Minimum clearance distance between HV circuit and LV circuit+earth [mm]	40
Minimum creepage distance [mm]	80
Comparative Tracking Index (CTI) (IEC 60112) [V]	600

² Device cabled according IEC 60947 ³ In new and clean condition for power loss calculation only

⁴ Other mounting positions not allowed

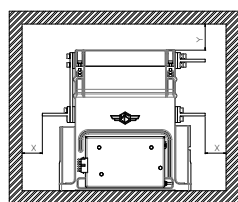

HORIZONTAL MOUNTING⁴

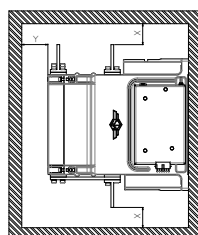

VERTICAL MOUNTING⁴

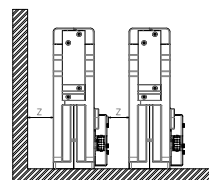

Minimum clearances [mm] from:

Rated Operational Voltage		X	Y	Z
3600V	Metal Parts	50	50	30
	Plastic Parts	30	30	30

Mechanical Characteristics

Mechanical Endurance (cycles)	2.5x10 ⁵
Shock and Vibrations (IEC61373)	Cat. 1 - Class B
Weight [kg]	11

Control Circuit

Control Voltage Range	0.7U _c ÷ 1.25U _c
Power Consumption (U _c and T = 20°C) at Pick up - when operating - at Holding [W]	100 - 30 - 0
Mechanical Operation Time (U _c and T = 20°C) when Closing - Opening [ms]	3000 - 3000
Mechanical Operation Time (in the worst condition) [ms]	4000 - 4000
Electrical Connections	Low voltage connector SMS 18GE63

Auxiliary Contacts

Tips material	Silver Alloy
Rated Operational voltage [V _{ac} / V _{dc}]	250
Rated Current [A]	5

Environmental Conditions

Stock Temperature Range	-50°C ÷ +85°C
Operational Temperature Range up to 1000m	Tx (-40°C ÷ +75°C) ⁵
Operational Temperature Range up to 2000m	T2 (-40°C ÷ +65°C) ⁵
Humidity	10 ÷ 95% RH ⁶

⁵ According to IEC50125-1

⁶ According to IEC 62498-1

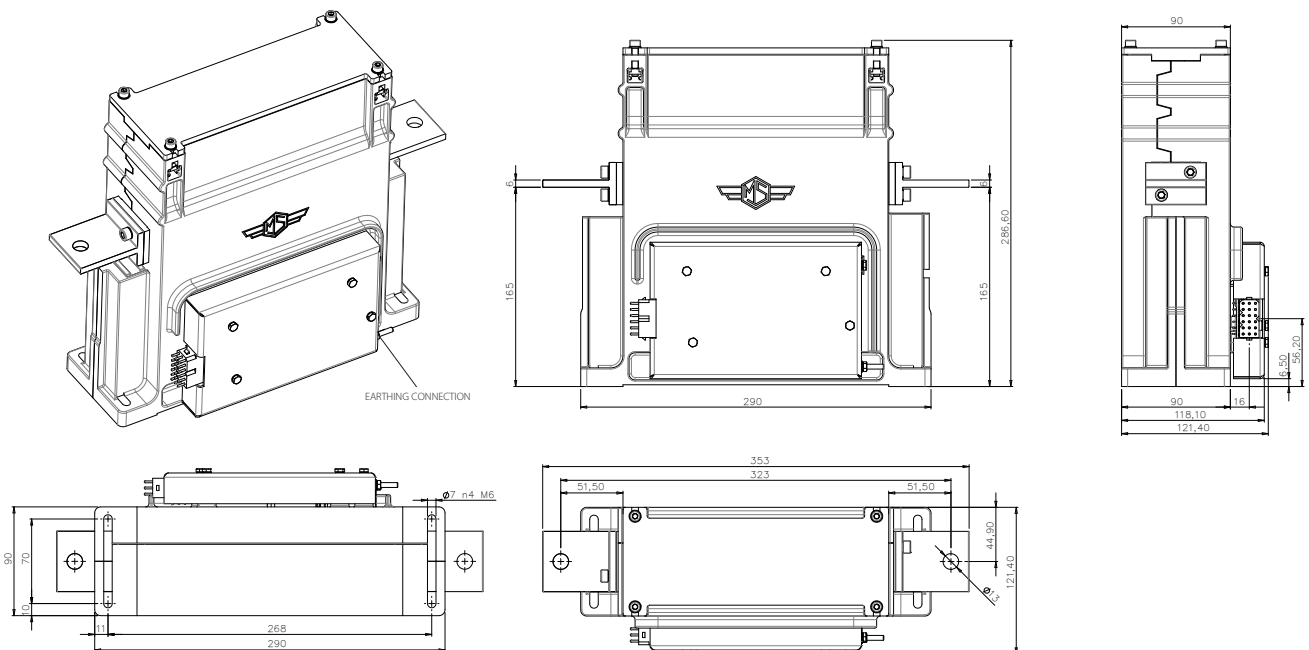

The technical specifications reported are not binding and they should be agreed in the contract.

For further technical information on our products visit www.microelettrica.com

Microelettrica Scientifica S.p.A.

20090 Buccinasco (MI) , Via Lucania 2, Italy

Tel.: +39 02 575731

E-mail: info@microelettrica.com

www.microelettrica.com

