

# SWITCHES

## STANDARD FAMILY CODE LTHS04011DAA0

Family Type	LTHS 400
Number / Type of Poles	1 / NO
Mounting Position	Horizontal - Vertical <sup>1</sup>
Control Voltage Rating Uc (DC) [V]	24 - 36 - 48 - 72 - 110 <sup>1</sup>
Auxiliary Contact Blocks	2 x (1 NO + 1 NC)
Block Type	PBX
Arc-chute Material	Ceramic
Main Contacts Tips Material	S6
Arcing Contacts Tips Material	-
Electric Diagram	-
Layout Drawing	D54085

<sup>1</sup> To be specified in order phase.



**MICROELETTRICA**

## Description

Contacteur with single interruption in air, electromagnetic control by full power coil. Single state functioning. Reference Standards IEC 60077, IEC 61992 and IEC 60947.

Insulation Characteristics		
Rated Operational Voltage (AC / DC)	[V]	1800 / 900
Max Operational Voltage (AC / DC)	[V]	2000
Rated Insulation Voltage	[V]	2000
Rated Impulse Voltage	[kV]	12
Rated Power Frequency Withstand Voltage (50 Hz for 60 s)		
Between HV to LV Circuit + Earth	[V]	6000
Between Open Contacts	[V]	4700
Between Each Pole (if more than 1)	[V]	-
Between LV Circuit and Earth	[V]	1500
Minimum Clearance Distance between Open Contacts	[mm]	14
Minimum Clearance Distance between Power Circuit to Earth	[mm]	14
Minimum Creepage Distance between Power Circuit to Earth	[mm]	25
Comparative Tracking Index (CTI) (IEC 60112)	[V]	600
Electrical Characteristics		
Conventional Free Air Thermal Current at 40 °C <sup>2</sup>	[A]	500
Conventional Free Air Thermal Current at 75 °C <sup>2</sup>	[A]	400
DC - Rated Operational Current ( $\tau = 15$ ms)		
1800 V	[A]	225
900 V	[A]	665
DC - Maximum Breaking Capacity ( $\tau = 5$ ms)		
1800 V	[A]	600
900 V	[A]	1160
AC - Maximum Breaking Capacity ( $\cos\phi = 0,8$ ; 50 Hz)		
1800 V	[A]	800
900 V	[A]	2000
Component Category / Operational Frequency Class		A2 / C3
Rated Short Time Withstand Current	[kA]	10 (for 100 ms)
Critical Current Range	[A]	< 50 (U > 1500 VDC)
Fault Making Capacity	[kA]	8
Blow Out Circuit Type		Indirect Coil

<sup>2</sup> Device cabled according IEC 60947

<sup>3</sup> Other mounting positions not allowed, reduced distances should be approved by Microelettrica

### Minimum clearances [mm] from:

Rated Operational Voltage		X	Y	Z
1800 V	Metal Parts	120	50	50
	Plastic Parts	50	30	20

### Minimum clearances [mm] from:

Rated Operational Voltage		X	Y	Z
900 V	Metal Parts	100	50	30
	Plastic Parts	50	30	20

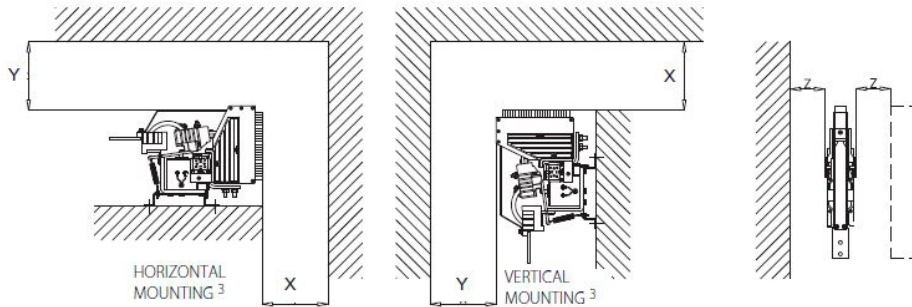

### Mechanical Characteristics

Mechanical Endurance	[cycles]	$2 \times 10^6$
Shock and Vibrations (IEC 61373)		Cat.1 - Class B
Weight	[kg]	13

### Control Circuit

Control Voltage Range	[V]	$0.7U_c \div 1.25U_c$
Power Consumption ( $U_c$ and $T = 20^\circ\text{C}$ ) at Pick Up - when Holding	[W]	40 - 40
Mechanical Operation Time ( $U_c$ and $T = 20^\circ\text{C}$ ) when Closing - Opening	[ms]	240 - 50
Time Constant (L/R) at Pick Up - when Holding	[ms]	130 - 170
Electrical Connections		Fast-on 6.35 x 0.8 mm

### Auxiliary Contact

Rated Operational Voltage (AC / DC)	[V]	250
Conventional Free Air Thermal Current at $40^\circ\text{C}$	[A]	10
Tips Material		Silver Alloy (Optional: Golden Plated)
Minimum Let-through Current at 24 - 72 - 110 VDC <sup>4</sup>	[mA]	20(10) - 15(7.5) - 10(5) <sup>4</sup>
Electrical Connections		Fast-on 6.35 x 0.8 mm

### Environmental Conditions

Stock Temperature Range	[°C]	$-50 \div +85$
Operational Temperature Range	[°C]	$T_x (-40 \div +75)^5$
Pollution Degree - Overvoltage Category (EN 50124-1)		PD3 - OV3
Max Altitude without Performance Derating	[m]	2000

<sup>4</sup> Reference Standard IEC 60947-5-4. Tested in a DRY and CLEAN condition with an LR load. The values with golden plated tips are indicated between brackets. For different working conditions, please contact Microelettrica

<sup>5</sup> According to IEC 50125-1

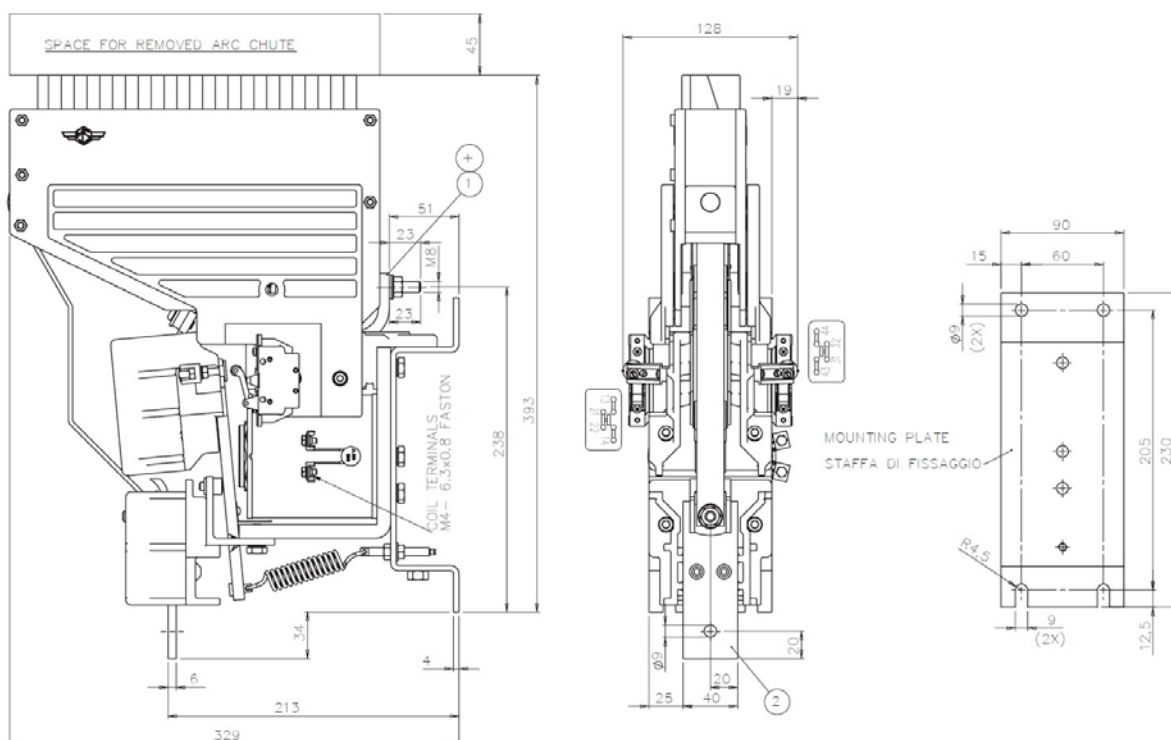

The technical specifications reported are not binding and they should be agreed in the contract.

**For further technical information on our products visit [www.microelettrica.com](http://www.microelettrica.com)**

**Microelettrica Scientifica S.p.A.**

20090 Buccinasco (MI) , Via Lucania 2, Italy

Tel.: +39 02 575731

E-mail: [info@microelettrica.com](mailto:info@microelettrica.com)

[www.microelettrica.com](http://www.microelettrica.com)



**KNORR-BREMSE**



**NEW YORK AIR BRAKE**



**IFE**



**MERAK**



**MICROELETTRICA**



**SELECTRON**



**EVAC**



**ZELISKO**



**RAILSERVICES**