

# SWITCHES

## STANDARD FAMILY CODE LTC003003\*A01

Family Type	LTC 300
Number / Type of Poles	3 / NO
Mounting Position	Horizontal - Vertical <sup>1</sup>
Control Voltage Rating Uc (DC) [V]	24 - 36 - 48 - 72 - 110 <sup>1</sup>
Auxiliary Contact Blocks	2 x (1 NO + 1 NC)
Block Type	SL
Arc-chute Material	Polyester Resin - Ceramic <sup>1</sup>
Main Contacts Tips Material	S6
Arcing Contacts Tips Material	-
Electric Diagram	-
Polyester Resin Layout Drawing	D54844
Ceramic Layout Drawing	D54875

<sup>1</sup> To be specified in order phase.



**MICROELETTRICA**

## Description

Contactors with double interruption in air, electromagnetic control by delayed auxiliary switch power system for double winding coil. Single state functioning. Reference Standards IEC 60077, IEC 61992 and IEC 60947.

Insulation Characteristics			
Rated Operational Voltage (AC / DC)	[V]	1800 / 900 / 440	
Max Operational Voltage (AC / DC)	[V]	2000	
Rated Insulation Voltage	[V]	2000	
Rated Impulse Voltage	[kV]	12	
Rated Power Frequency Withstand Voltage (50 Hz for 60 s)			
Between HV to LV Circuit + Earth	[V]	6000	
Between Open Contacts	[V]	4700	
Between Each Pole (if more than 1)	[V]	6000	
Between LV Circuit and Earth	[V]	1500	
Minimum Clearance Distance between Open Contacts	[mm]	10	
Minimum Clearance Distance between Power Circuit to Earth	[mm]	14	
Minimum Creepage Distance between Power Circuit to Earth	[mm]	25	
Comparative Tracking Index (CTI) (IEC 60112)	[V]	600	
Electrical Characteristics			
Arc-chute		Polyester Resin	Ceramic
Conventional Free Air Thermal Current at 40 °C <sup>2</sup>	[A]	300	300
Conventional Free Air Thermal Current at 75 °C <sup>2</sup>	[A]	270	270
DC - Rated Operational Current (τ = 15 ms)			
1800 V	[A]	-	-
900 V	[A]	-	-
440 V	[A]	-	-
DC - Maximum Breaking Capacity (τ = 5 ms)			
1800 V	[A]	-	-
900 V	[A]	-	-
440 V	[A]	-	-
AC - Maximum Breaking Capacity (cosφ = 0,8; 50 Hz) <sup>3</sup>			
1800 V	[A]	80	100
900 V	[A]	160	200
440 V	[A]	320	400
Component Category / Operational Frequency Class		A2 / C3	A2 / C3
Rated Short Time Withstand Current	[kA]	5 (for 100 ms)	5 (for 100 ms)
Critical Current Range	[A]	DC Reverse Current	DC Reverse Current
Fault Making Capacity	[kA]	2.4	2.4
Blow Out Circuit Type		Permanent Magnet	Permanent Magnet

<sup>2</sup> Device cabled according IEC 60947

<sup>3</sup> Line current, voltage between lines

<sup>4</sup> Other mounting positions not allowed, reduced distances should be approved by Microelettrica

### Minimum clearances [mm] from:

Rated Operational Voltage		X	Y	Z
1800 V	Metal Parts	120	120	50
	Plastic Parts	50	50	20

### Minimum clearances [mm] from:

Rated Operational Voltage		X	Y	Z
900 V	Metal Parts	100	100	30
	Plastic Parts	50	50	20

### Minimum clearances [mm] from:

Rated Operational Voltage		X	Y	Z
900 V	Metal Parts	100	100	30
	Plastic Parts	50	50	20

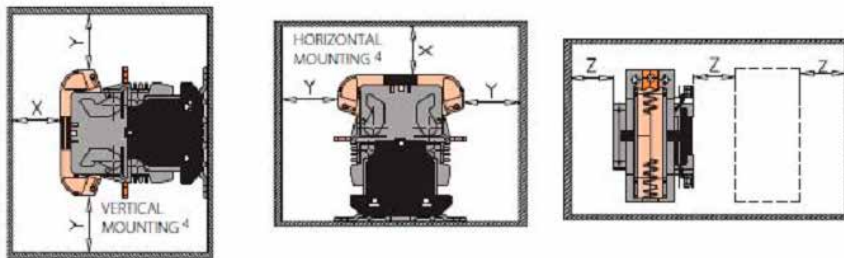

### Mechanical Characteristics

Mechanical Endurance	[cycles]	$2 \times 10^6$
Shock and Vibrations (IEC 61373)		Cat.1 - Class B
Weight	[kg]	5

### Control Circuit

Control Voltage Range	[V]	$0.7U_c \div 1.25U_c$
Power Consumption ( $U_c$ and $T = 20^\circ\text{C}$ ) at Pick Up - when Holding	[W]	100 - 20
Mechanical Operation Time ( $U_c$ and $T = 20^\circ\text{C}$ ) when Closing - Opening	[ms]	50 - 20
Time Constant (L/R) at Pick Up - when Holding	[ms]	25 - 80
Electrical Connections		Fast-on 6.35 x 0.8 mm

### Auxiliary Contact

Rated Operational Voltage (AC / DC)	[V]	250
Conventional Free Air Thermal Current at $40^\circ\text{C}$	[A]	10
Tips Material		Silver Alloy (Optional: Golden Plated)
Minimum Let-through Current at 24 - 72 - 110 VDC <sup>5</sup>	[mA]	20(10) - 15(7.5) - 10(5) <sup>5</sup>
Electrical Connections		Fast-on 6.35 x 0.8 mm

### Environmental Conditions

Stock Temperature Range	[°C]	$-50 \div +85$
Operational Temperature Range	[°C]	$T_x (-40 \div +75)^6$
Pollution Degree - Overvoltage Category (EN 50124-1)		PD3 - OV3
Max Altitude without Performance Derating	[m]	2000

<sup>5</sup> Reference Standard IEC 60947-5-4. Tested in a DRY and CLEAN condition with an LR load. The values with golden plated tips are indicated between brackets. For different working conditions, please contact Microelettrica

<sup>6</sup> According to EN 50125-1

## Polyester Resin Layout Drawing

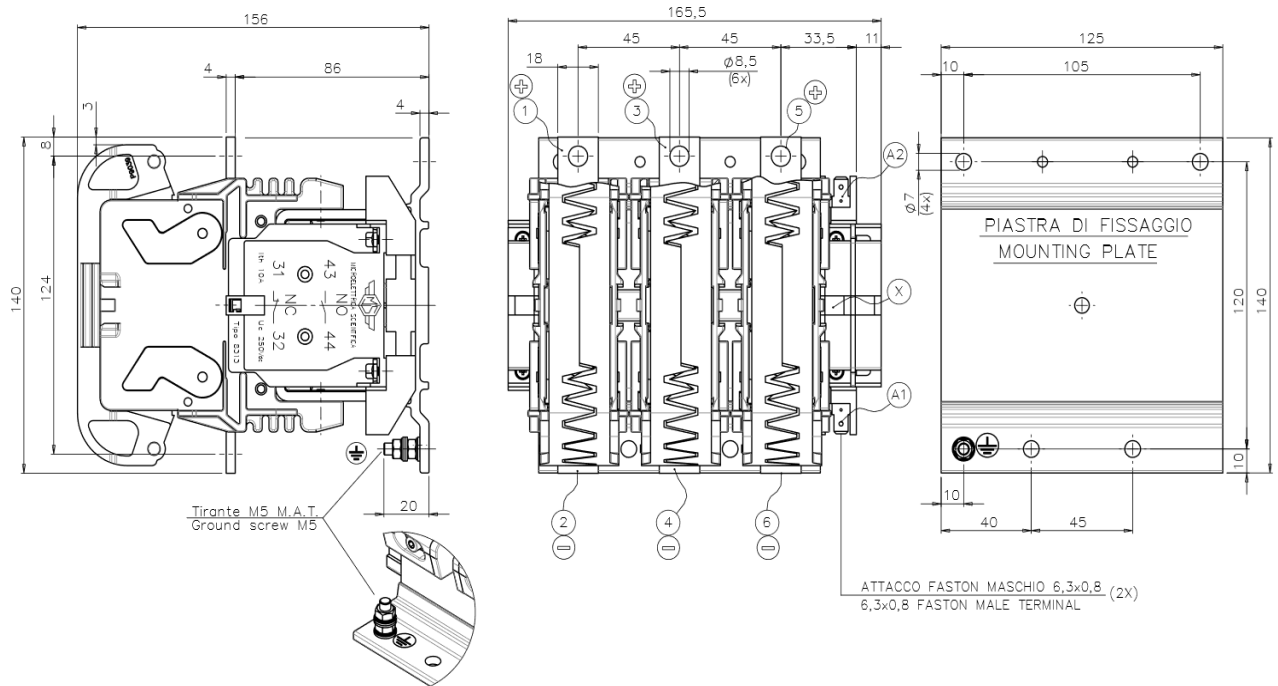

## Ceramic Layout Drawing

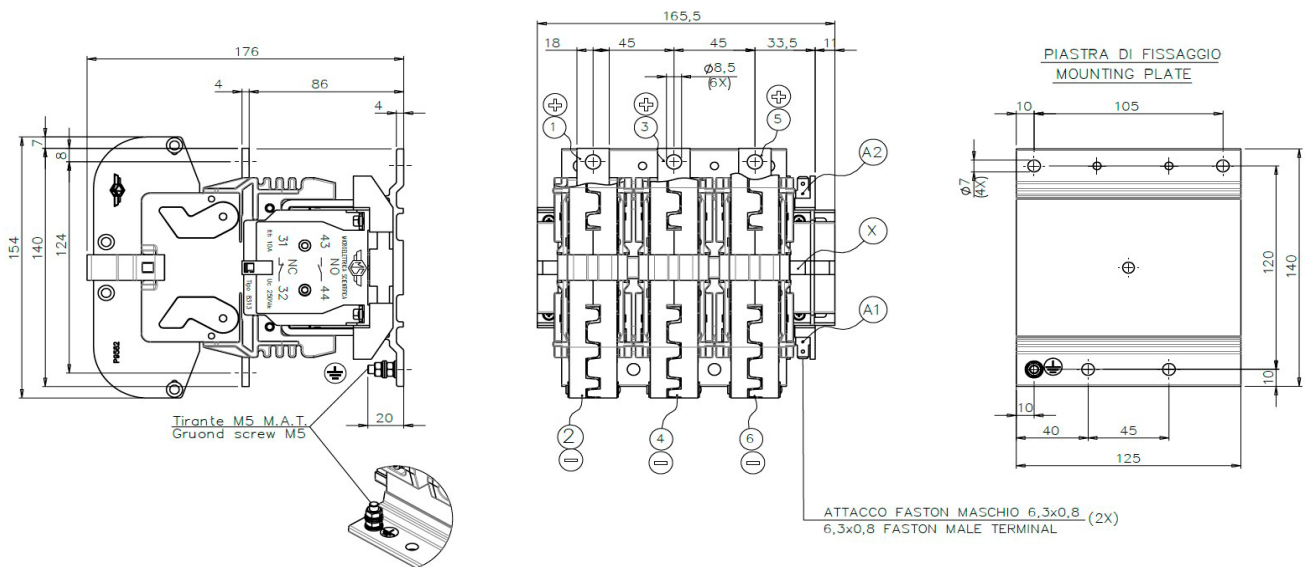

The technical specifications reported are not binding and they should be agreed in the contract.

For further technical information on our products visit [www.microelettrica.com](http://www.microelettrica.com)

**Microelettrica Scientifica S.p.A.**

20090 Buccinasco (MI) , Via Lucania 2, Italy

Tel.: +39 02 575731

E-mail: [info@microelettrica.com](mailto:info@microelettrica.com)

[www.microelettrica.com](http://www.microelettrica.com)

