

SWITCHES

STANDARD FAMILY CODE LTC003001*A00

Family Type	LTC 300
Number / Type of Poles	1 / NO
Mounting Position	Horizontal - Vertical ¹
Control Voltage Rating U _c (DC) [V]	24 - 36 - 48 - 72 - 110 ¹
Auxiliary Contact Blocks	2 x (1 NO + 1 NC)
Block Type	SL
Arc-chute Material	Polyester Resin - Ceramic ¹
Main Contacts Tips Material	S6
Arcing Contacts Tips Material	-
Electric Diagram	-
Polyester Resin Layout Drawing	D55015
Ceramic Layout Drawing	D55016



MICROELETTRICA

Description

Contactors with double interruption in air, electromagnetic control full power coil. Single state functioning. Reference Standards IEC 60077, IEC 61992, IEC 60947 and GOST 9219-88.

Insulation Characteristics			
Rated Operational Voltage (AC / DC)	[V]	1800 / 900 / 440	
Max Operational Voltage (AC / DC)	[V]	2000	
Rated Insulation Voltage	[V]	2000	
Rated Impulse Voltage	[kV]	12	
Rated Power Frequency Withstand Voltage (50 Hz for 60 s)			
Between HV to LV Circuit + Earth	[V]	6000	
Between Open Contacts	[V]	4700	
Between Each Pole (if more than 1)	[V]	-	
Between LV Circuit and Earth	[V]	1500	
Minimum Clearance Distance between Open Contacts	[mm]	10	
Minimum Clearance Distance between Power Circuit to Earth	[mm]	14	
Minimum Creepage Distance between Power Circuit to Earth	[mm]	25	
Comparative Tracking Index (CTI) (IEC 60112)	[V]	600	
Electrical Characteristics			
Arc-chute		Polyester Resin	Ceramic
Conventional Free Air Thermal Current at 40 °C ²	[A]	300	300
Conventional Free Air Thermal Current at 75 °C ²	[A]	270	270
DC - Rated Operational Current (τ = 15 ms)			
1800 V	[A]	16	20
900 V	[A]	65	100
440 V	[A]	130	200
DC - Maximum Breaking Capacity (τ = 5 ms)			
1800 V	[A]	25	30
900 V	[A]	130	150
440 V	[A]	195	225
AC - Maximum Breaking Capacity (cosφ = 0,8; 50 Hz)			
1800 V	[A]	80	100
900 V	[A]	160	200
440 V	[A]	320	400
Component Category / Operational Frequency Class		A2 / C3	A2 / C3
Rated Short Time Withstand Current	[kA]	5 (for 100 ms)	5 (for 100 ms)
Critical Current Range	[A]	DC Reverse Current	DC Reverse Current
Fault Making Capacity	[kA]	2.4	2.4
Blow Out Circuit Type		Permanent Magnet	Permanent Magnet

GOST recognized		
Nominal Voltage (AC / DC)	[V]	3000
Max Operational Voltage (AC / DC)	[V]	4000
Commutation Ability according to GOST 9219-88		
Critical Commutation Ability @ 4000Vdc (L=50mH)	[A]	20
Maximum Commutation Ability @ 4000Vdc (L=100mH)	[A]	200
Stipulated Commutation Ability @ 3000Vdc (L=225mH)	[A]	200
Shock and Vibrations (GOST 30631)		M25
Minimum environment air working temperature according to GOST 9219-88	[°C]	-60
Minimum Insulance Resistance (NCC/Heat-resistance/humidity)	[MOhm]	100 / 10 / 0.5
Mechanical Characteristics		
Mechanical Endurance	[cycles]	2 x 10 ⁶
Shock and Vibrations (IEC 61373)		Cat.1 - Class B
Weight	[kg]	2
Control Circuit		
Control Voltage Range	[V]	0.7Uc ÷ 1.25Uc
Power Consumption (Uc and T = 20 °C) at Pick Up - when Holding	[W]	32 - 32
Mechanical Operation Time (Uc and T = 20 °C) when Closing - Opening	[ms]	50 - 20
Time Constant (L/R) at Pick Up - when Holding	[ms]	25 - 50
Electrical Connections		Fast-on 6.35 x 0.8 mm
Auxiliary Contact		
Rated Operational Voltage (AC / DC)	[V]	250
Conventional Free Air Thermal Current at 40 °C	[A]	10
Tips Material		Silver Alloy (Optional: Golden Plated)
Minimum Let-through Current at 24 - 72 - 110 VDC ⁴	[mA]	20(10) - 15(7.5) - 10(5) ⁴
Electrical Connections		Fast-on 6.35 x 0.8 mm

¹ To be specified in order phase.

² Device cabled according IEC 60947

³ Other mounting positions not allowed, reduced distances should be approved by Microelettrica

⁴ Reference Standard IEC 60947-5-4. Tested in a DRY and CLEAN condition with an LR load. The values with golden plated tips are indicated between brackets. For different working conditions, please contact Microelettrica

Minimum clearances [mm] from:				
Rated Operational Voltage		X	Y	Z
1800 V	Metal Parts	120	120	50
	Plastic Parts	50	50	20

Minimum clearances [mm] from:				
Rated Operational Voltage		X	Y	Z
900 V	Metal Parts	100	100	30
	Plastic Parts	50	50	20

Minimum clearances [mm] from:				
Rated Operational Voltage		X	Y	Z
440 V	Metal Parts	100	100	30
	Plastic Parts	50	50	20

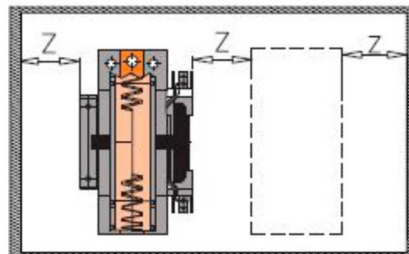
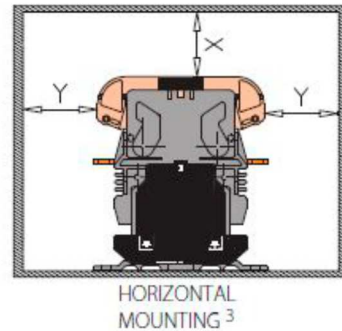
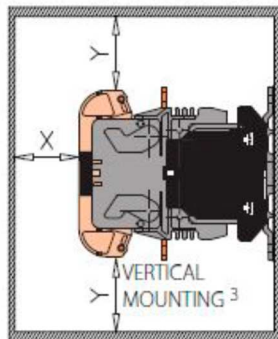

Environmental Conditions

Stock Temperature Range	[°C]	-50 ÷ +85
Operational Temperature Range	[°C]	Tx (-40 ÷ +75) ⁵
Pollution Degree - Overvoltage Category (EN 50124-1)		PD3 - OV3
Max Altitude without Performance Derating	[m]	2000

⁵ According to EN 50125-1

Polyester Resin Layout Drawing

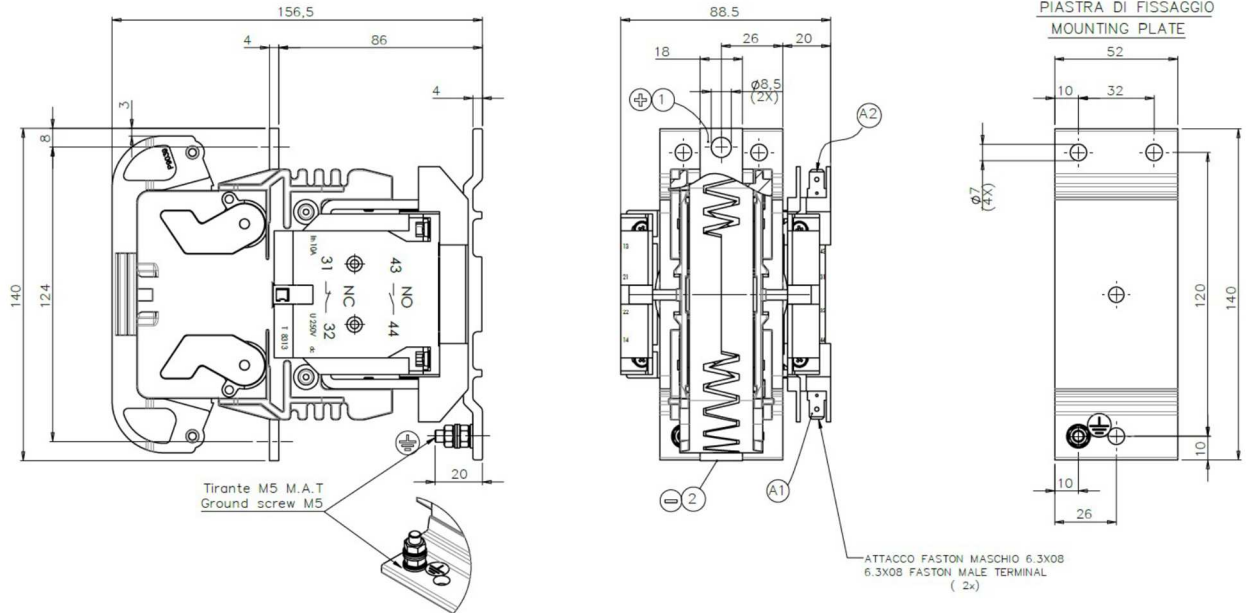

Ceramic Layout Drawing

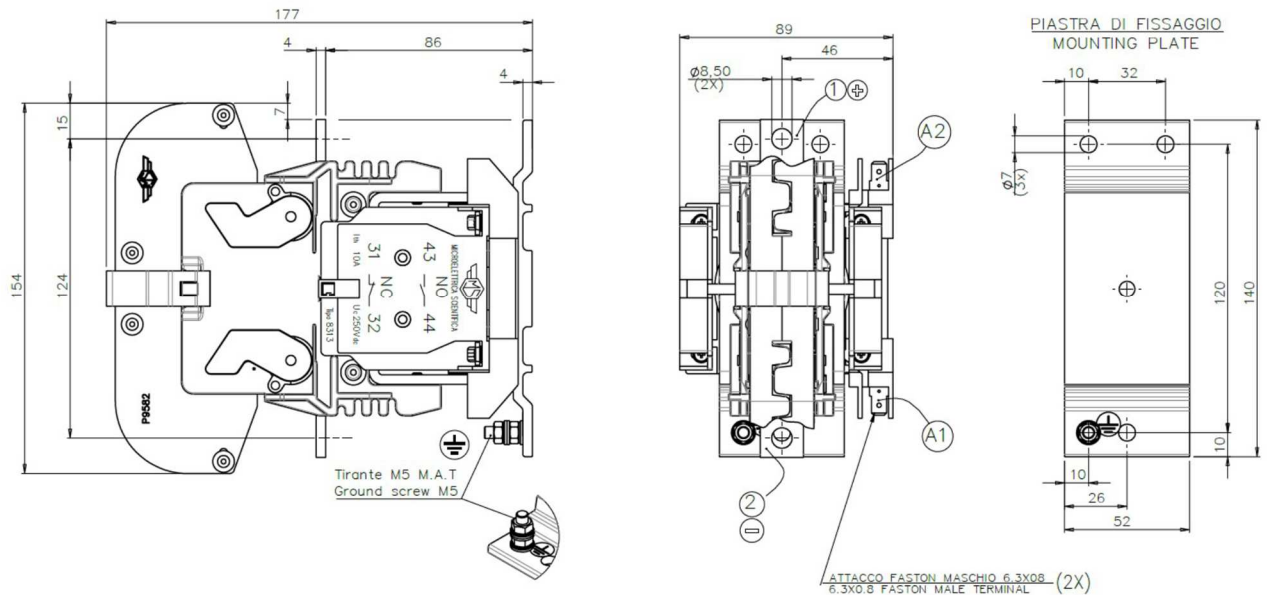

The technical specifications reported are not binding and they should be agreed in the contract.

For further technical information on our products visit www.microelettrica.com

Microelettrica Scientifica S.p.A.

20090 Buccinasco (MI) , Via Lucania 2, Italy

Tel.: +39 02 575731

E-mail: info@microelettrica.com

www.microelettrica.com



KNORR-BREMSE

NEW YORK AIR BRAKE

IFE

MERAK

MICROELETTRICA

SELECTRON

EVAC

ZELISKO

RAILSERVICES