

SWITCHES

STANDARD FAMILY CODE LTC002502*A02

Family Type	LTC 250
Number / Type of Poles	2 / NO
Mounting Position	Horizontal - Vertical ¹
Connection between Poles	Series
Control Voltage Rating Uc (DC) [V]	24 - 36 - 48 - 72 - 110 ¹
Auxiliary Contact Blocks	2 x (1 NO + 1 NC)
Block Type	SL
Arc-chute Material	Polyester Resin - Ceramic ¹
Main Contacts Tips Material	S6
Arcing Contacts Tips Material	-
Electric Diagram	-
Polyester Resin Layout Drawing	D54646
Ceramic Layout Drawing	D54711

¹ To be specified in order phase.



MICROELETTRICA

Description

Contactors with double interruption in air, electromagnetic control by full power coil. Single state functioning. Reference Standards IEC 60077, IEC 61992 and IEC 60947.

Insulation Characteristics			
Rated Operational Voltage (AC / DC)		[V]	1800 / 900
Max Operational Voltage (AC / DC)		[V]	2000
Rated Insulation Voltage		[V]	2000
Rated Impulse Voltage		[kV]	12
Rated Power Frequency Withstand Voltage (50 Hz for 60 s)			
Between HV to LV Circuit + Earth		[V]	6000
Between Open Contacts		[V]	4700
Between Each Pole (if more than 1)		[V]	6000
Between LV Circuit and Earth		[V]	1500
Minimum Clearance Distance between Open Contacts		[mm]	20
Minimum Clearance Distance between Power Circuit to Earth		[mm]	14
Minimum Creepage Distance between Power Circuit to Earth		[mm]	25
Comparative Tracking Index (CTI) (IEC 60112)		[V]	600
Electrical Characteristics			
Arc-chute		Polyester Resin	Ceramic
Conventional Free Air Thermal Current at 40 °C ²	[A]	250	250
Conventional Free Air Thermal Current at 75 °C ²	[A]	200	200
DC - Rated Operational Current (τ = 15 ms)			
1800 V	[A]	100	150
900 V	[A]	205	300
DC - Maximum Breaking Capacity (τ = 5 ms)			
1800 V	[A]	200	250
900 V	[A]	415	500
AC - Maximum Breaking Capacity (cosφ = 0,8; 50 Hz)			
1800 V	[A]	300	320
900 V	[A]	660	720
Component Category / Operational Frequency Class		A2 / C3	A2 / C3
Rated Short Time Withstand Current	[kA]	5 (for 100 ms)	5 (for 100 ms)
Critical Current Range	[A]	DC Reverse Current	DC Reverse Current
Fault Making Capacity	[kA]	2.4	2.4
Blow Out Circuit Type		Permanent Magnet	Permanent Magnet

² Device cabled according IEC 60947 ³ Other mounting positions not allowed, reduced distances should be approved by Microelettrica

Minimum clearances [mm] from:

Rated Operational Voltage		X	Y	Z
1800 V	Metal Parts	120	120	50
	Plastic Parts	50	50	20

Minimum clearances [mm] from:

Rated Operational Voltage		X	Y	Z
900 V	Metal Parts	100	100	30
	Plastic Parts	50	50	20

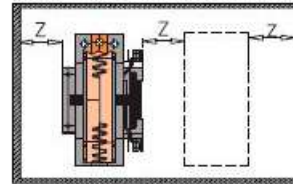
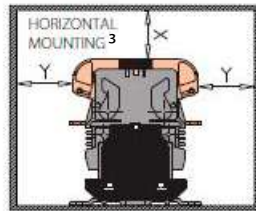
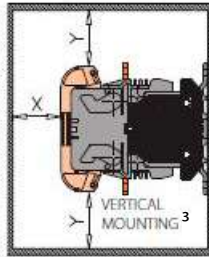
**Mechanical Characteristics**

Mechanical Endurance	[cycles]	2×10^6
Shock and Vibrations (IEC 61373)		Cat.1 - Class B
Weight	[kg]	3.5

Control Circuit

Control Voltage Range	[V]	$0.7U_c \div 1.25U_c$
Power Consumption (U_c and $T = 20^\circ\text{C}$) at Pick Up - when Holding	[W]	35 - 35
Mechanical Operation Time (U_c and $T = 20^\circ\text{C}$) when Closing - Opening	[ms]	55 - 25
Time Constant (L/R) at Pick Up - when Holding	[ms]	25 - 85
Electrical Connections		Fast-on 6.35 x 0.8 mm

Auxiliary Contact

Rated Operational Voltage (AC / DC)	[V]	250
Conventional Free Air Thermal Current at 40°C	[A]	10
Tips Material		Silver Alloy (Optional: Golden Plated)
Minimum Let-through Current at 24 - 72 - 110 VDC ⁴	[mA]	20(10) - 15(7.5) - 10(5) ⁴
Electrical Connections		Fast-on 6.35 x 0.8 mm

Environmental Conditions

Stock Temperature Range	[°C]	$-50 \div +85$
Operational Temperature Range	[°C]	$T_x (-40 \div +75)^5$
Pollution Degree - Overvoltage Category (EN 50124-1)		PD3 - OV3
Max Altitude without Performance Derating	[m]	2000

⁴ Reference Standard IEC 60947-5-4. Tested in a DRY and CLEAN condition with an LR load. The values with golden plated tips are indicated between brackets. For different working conditions, please contact Microelettrica

⁵ According to EN 50125-1

Polyester Resin Layout Drawing

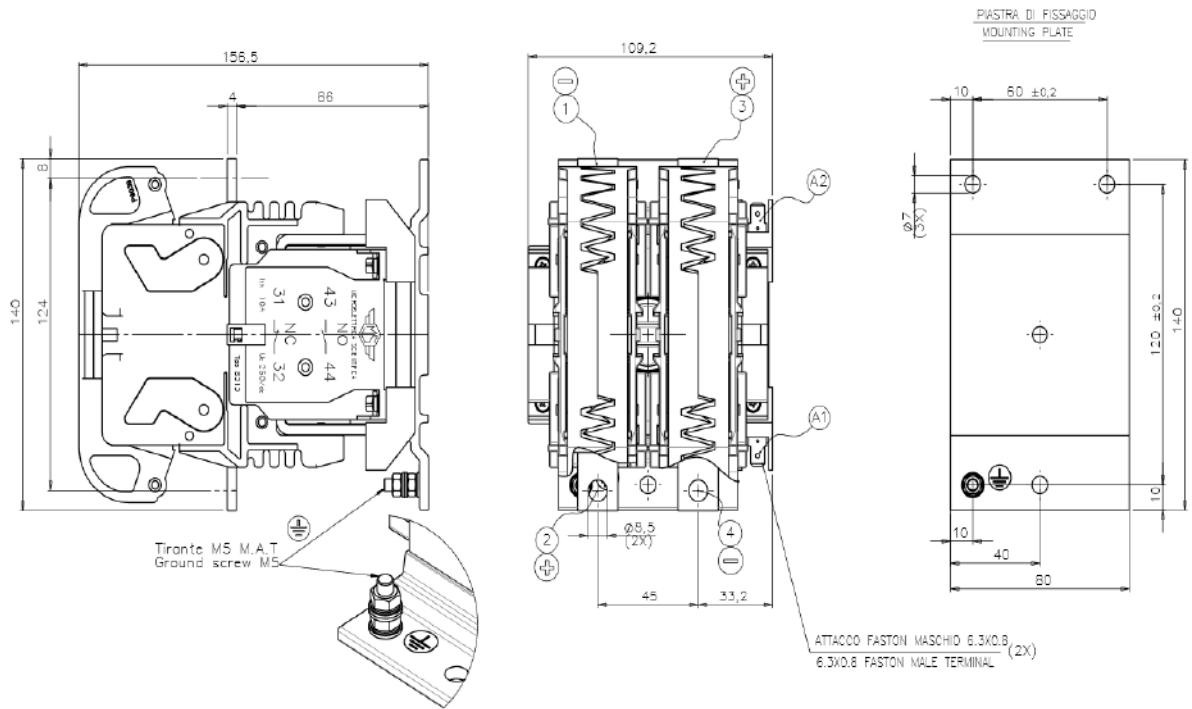

Ceramic Layout Drawing

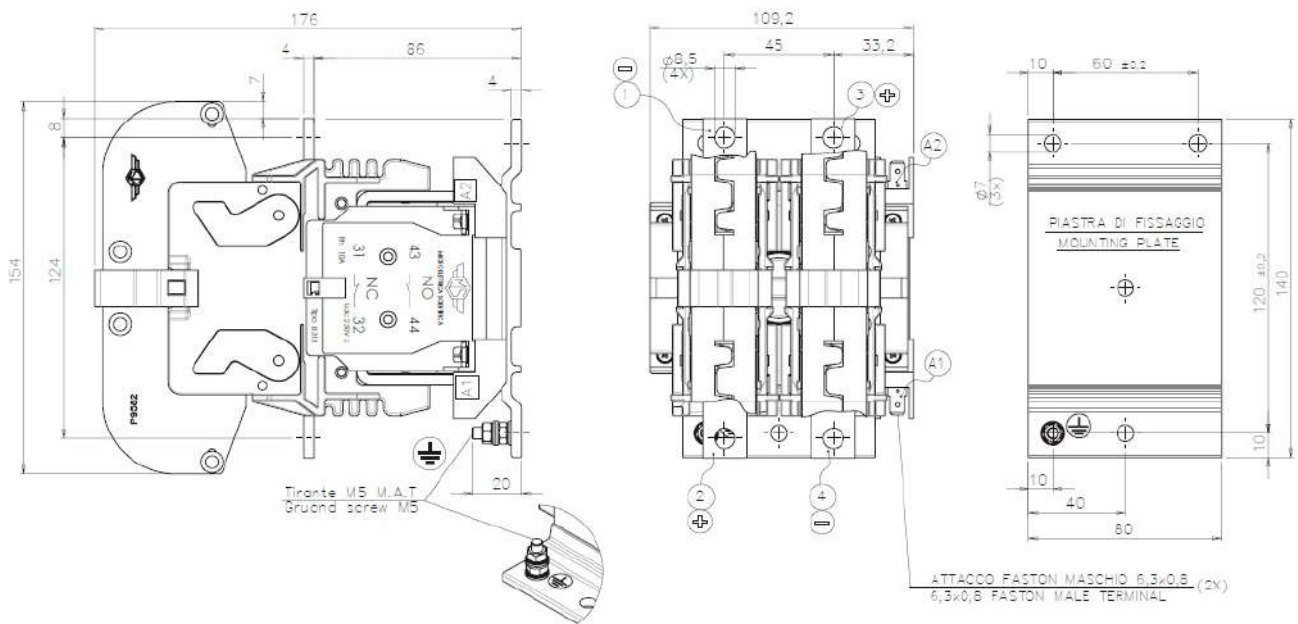

The technical specifications reported are not binding and they should be agreed in the contract.

For further technical information on our products visit www.microelettrica.com

Microelettrica Scientifica S.p.A.

20090 Buccinasco (MI) , Via Lucania 2, Italy

Tel.: +39 02 575731

E-mail: info@microelettrica.com

www.microelettrica.com

